

# VEER SURENDRA SAI UNIVERSITY OF TECHNOLOGY, ODISHA

PO: Burla Engineering College  
Dist.: Sambalpur, PIN-768018  
Odisha. [www.vssut.ac.in](http://www.vssut.ac.in)



Phone: +91-663-2430211  
Fax: +91-663-2430204  
PBX: +91-663-2430-589-592

No.-VSSUT/DSW/ 141 /16

Dated: 15.03.2016

## **Tender Call Notice for Supply of Furniture for Halls of Residence**

Registrar, Veer Surendra Sai University of Technology, Burla (VSSUT) invites offers from the Manufacturer/Authorized firms for supply of furniture for Halls of Residence of the University. Tender papers with all specifications, terms and conditions will be available in the official website of the University ([www.vssut.ac.in](http://www.vssut.ac.in)) which can be downloaded and submitted after filling it up completely. The cost of the tender paper is Rs. 600/- which can be paid in the form of a demand draft drawn in favour of VSSUT, Burla from any nationalized bank, payable at Burla. The DD towards the cost of the tender paper must be submitted along with the tender paper, otherwise the tender paper shall be liable for rejection.

Sealed tenders accompanied by refundable noninterest bearing earnest money deposit of Rs.50,000/- (Rupees Fifty thousand only) in the form of DD from any nationalized Bank drawn in favour of VSSUT, Burla, payable at Burla with name of the work and name of the bidder written on the envelopes will be received at the office of the Registrar, Veer Surendra Sai University of Technology, Burla on or before 07.04.2016 up to 4.30 PM. The demand draft for EMD is to be attached with **Technical Bid**. Tenders not accompanied with EMD will not be considered. The tenders will be opened at the Office of the Dean Students' Welfare on 11.04.2016 at 3.00PM.

The tenders are to be submitted only by Registered Post/speed Post. No hand delivery shall be accepted.

### **IMPORTANT DATES:**

<b>Last date for submission of tender papers</b>	<b>4.30PM of 07.04.2016</b>
<b>Opening of tender Papers</b>	<b>3.00PM of 11.04.2016</b>

## **GENERAL TERMS & CONDITIONS**

1. The requirement of the furniture is in respect of Halls of Residence at Burlaand these are to be delivered at site only.
2. The supplier must supply all items at a time, part supply will not be acceptable. Any loss or damage during the transit will be solely borne by the supplier.
3. The rates to be quoted only for furniture conforming to technical specifications, inclusive of all charges and Taxes.
4. The tender comprises two parts i.e. 1. Technical bid and 2. Financial Bid. The first part is technical bid where the vendor is required to give the details of the firm and the confirmation on technical specification. If there is noncompliance in respect of any item, all details thereof must be provided. The second part is financial bid where the vendor is required to quote the rates only. No other information/condition is to be mentioned in the financial bid. Conditions if any, are to be given in the technical bid only. The technical and financial bids are to be submitted in separate envelopes.
5. The bidder shall quote the rates in figures as well as in words. The amount of each item shall be worked out and requisite total to be given.
6. Each tender document is required to be signed by the authorized person or persons submitting the tenders in token of his/her having acquainted himself/themselves with the general terms and conditions, specifications and schedule of quantities etc. as laid down. Any tender with any of the tender documents not so signed are liable to be rejected.
7. Tender should be filled with neat legible and correct entries. Indistinct figures should be avoided. Any erasures and alterations made while filling the tender or figure/figures are not permitted. Failure to comply with either of these conditions will render the tender void. No advice of any change in rate or conditions after opening of the will be entertained.
8. The undersigned does not bind himself to accept the lowest or any tender and reserve to itself the right of accepting the whole or any part of the tender and the vendor shall be bound to perform the same at the rate quoted.
9. Taxes shall be payable extra. However, components of taxes must be mentioned in the price bid with all relevant bifurcation/information. All transportation charges shall be payable by the vendor and Registrar, VSSUT will not entertain any claim whatsoever in this respect.
10. No escalation in price shall be allowed after the award of tenders. It is clarified that change in taxes shall not be treated as price variation.
11. The bidder shall not sublet the work entrusted to him without the prior written permission of the authority.
12. Only first make of material has to be used. No advance payment will be made.
13. The bidder firm should be ISO- 9001:2008 certified.
14. The annual turnover of the participating firm should be more than Rs. 1.00 Cr. during the last financial year.

15. The warranty periods for the items shall be two years from the date of receipt of the materials.
16. The EMD amount of the successful bidder will be kept as retention money and will be released only after expiry of the warranty period.. However, the EMD amount of other bidders will be returned back after the tendering process is completed.
17. Only the bidders agreeing upon the above technical terms and conditions should submit their tenders in sealed covers. Technical bid shall include documentary proof in respect of each of the above points of Technical Terms & Conditions. Financial bids of firms, who fail to fulfil any of the above conditions, will not be considered.
18. The firm should also assure after sales service and should provide an undertaking that it will provide spares and services for at least next 3 years. In case of any breakdown the same may be attended & rectified within 48 hours. An undertaking to this office will be given by the bidders. If the vender fails to provide satisfactory service then the EMD deposit shall be forfeited.
19. The Technical bid shall contain, inter alia, the following essential documents specified as under:-

1	ITCC and VATCC with documentary proof.
2	Documentary proof of Authorized Distributor/Dealer/Supplier, as the case may be.
3	Details of satisfactory supply certificates/POs, if any, regarding supplies of similar nature.

20. Detailed specifications and tentative diagrams of the items have been provided herewith.
21. 100% Payment shall be made after delivery, installation and satisfactory acceptance.
22. The bidders shall present the samples of the furniture stated herein for inspection with respect to the specifications. If needed minor modifications may be suggested without any increase in quoted price with mutual agreement.
23. Liquidated Damages: In case of failure to execute the order in full within the specified period, liquidated damages shall be charged at the rate of ½% per week or part thereof but not exceeding 8% of the order value.
24. Registrar, VSSUT reserves the right to accept/reject any/all offers without assigning any reason whatsoever.
25. Any dispute arising out of the deal shall be subjected to the jurisdiction of the court at Sambalpur in the state of Odisha.

## TECHNICAL SPECIFICATIONS

S/N	Item Description & Specifications
1	<p><b>Cots:</b> 1828mm (L)×914mm (W) made by 25mm × 5mm MS angle with four legs of 40 mm round MS steel hollow pipe fitted with 19mm commercial ply with provision for mosquito stand on the legs. The height of the cot shall be 457mm (H). Two numbers of 25mm angle intermediate support for the frame must be provided. The legs shall be strengthened by joining two legs with the help of 25mm round pipe on both the sides (Fig.1). Cot should be properly primed red and then painted with oven backed painting with proper anti rust treatment. Rubber buffer must be fixed to four legs. All sides or joints must be welded properly (Joining various parts with nuts and bolts is not allowed).</p>
2	<p><b>Study Table:</b> Study table of Size 914mm (L) ×610mm (W)×762mm (H) made up of 18 gauge 1” size MS square pipe frame with 4 legs with PVC shoe and top periphery support bars and top with both side post form finish having 25mm MDF board with 1mm sunmica laminate of approved colour (Fig.2). The MS frame should be properly primed red and then be painted with oven baked painting with proper anti-rust treatment. All sides or joints must be welded properly (Joining various parts with nuts and bolts is not allowed).</p>
3	<p><b>Dining Table:</b> Dining Table of size 1800mm (L) × 914mm (W) × 750mm (H) made out of 16G stainless steel sheet. Frame of the dining table shall be made of SS square pipe of 25.4mm × 25.4mm × 1.5mm. 3 nos of square pipe of size 25.4mm × 25.4mm × 1.5 mm cross pipes to be provided in the frame for the top sheet support. 6 numbers of SS top stools with 25.4mm diameter seat and 1.5mm thickness to be provided and the stools to be attached permanently to the table. The legs for the table and the stools shall be of round SS pipe of 62mm diameter, 1.5mm thickness. 2 nos of SS round pipe 25.4mm diameter, 1.50mm thickness shall be provided parallel to the length of the table for support. 3 nos. of cross bars made up of round SS pipe of size 62mm diameter and 1.5mm thickness to be provided joining the legs of the table and the stools. Rubber bush to be provided at the bottom of every leg (Fig. 3). There should be proper machining (shearing, bending etc.) and welding finish.</p>
4	<p><b>Chair:</b> Moulded chair without arms of Neelkamal/Supreme or equivalent make.</p>

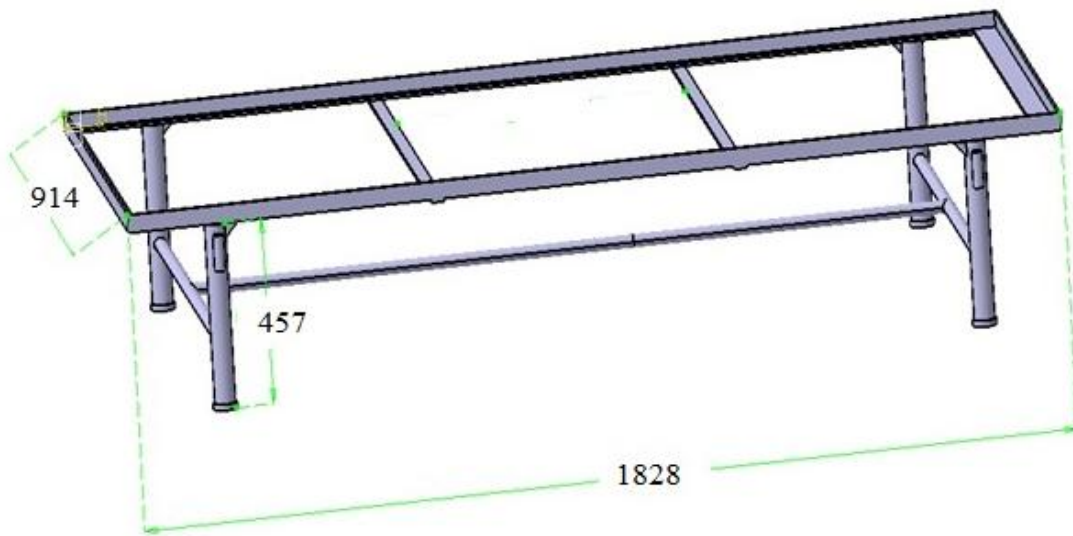

FIG.1- COT (Frame)

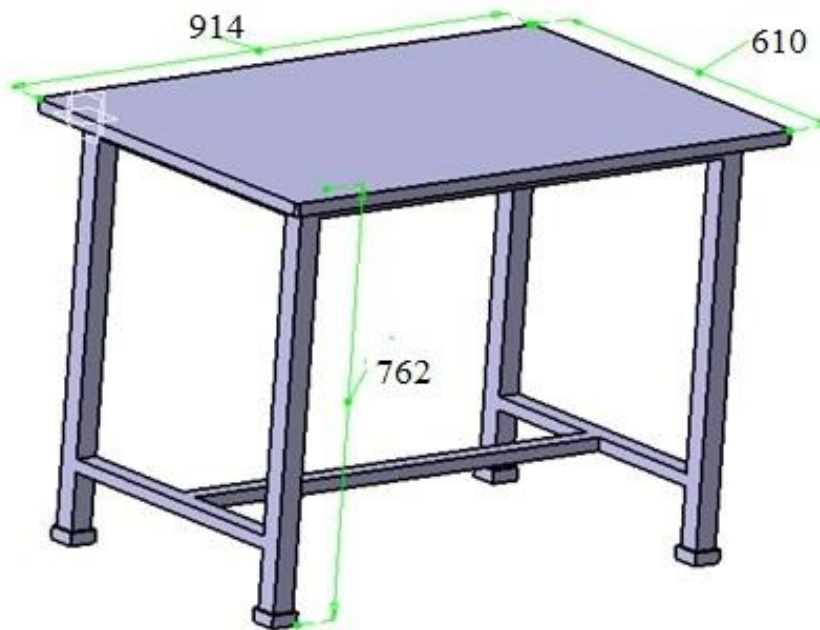

FIG.2- STUDY TABLE

NB- Figures not to scale  
All dimensions are in mm

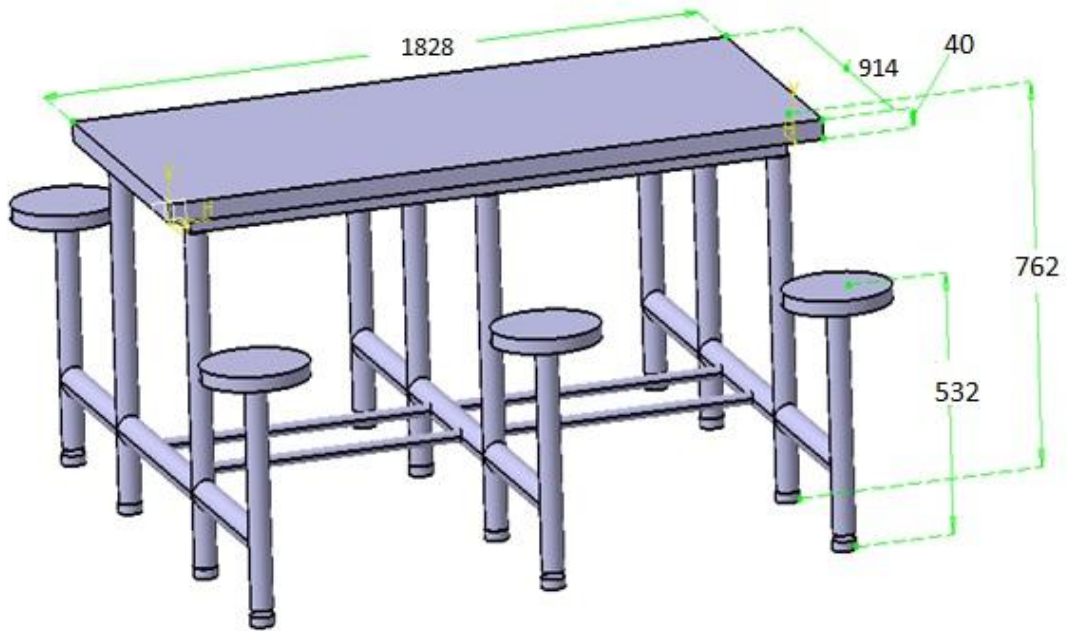

FIG.3- DINING TABLE

NB- Figures not to scale  
All dimensions are in mm

To,  
The Registrar  
VSSUT, Burla

**Sub: Supply of furniture for university Halls of Residence.**

Dear Sir,

I/We the undersigned have carefully gone through and clearly understood the specifications, quantities with **general conditions mentioned in the tender document for the above mentioned work** do hereby tender to execute and complete the supply of furniture in accordance with the priced bill of quantified and/or as given in the specification of the works.

It is understood that the lowest or any tender will not necessarily be accepted and that you are not bound to assign any reason thereof for the same.

I/We agree to keep our offer open for 90 days from the date of opening of tender.

**Having examined the schedule of quantities relating to the proposed tender for supply of furniture and having acquired the tenders invited by you, we the undersigned hereby offer to execute, complete and maintain the proposed work in strict accordance with the conditions and specifications described in the tender document at the item rates quoted by us in the tender.**

We undertake to complete and deliver the total work within the stipulated time period from the date of issue of work order by the competent authority. We are aware that the delay in completion of work will attract penalty as specified as per clause 23 of General Terms and conditions.

Place:

Signature & Stamp of Bidder

Date:

Name and address of the bidder

## TECHNICAL BID

**To be filled and signed by the authorized signatory of the firm & this is to be put in separate sealed cover superscribed with “Technical bid for furniture for VSSUT Hall of Residence”.**

1	Name of the firm	
2	Address	
3	Contact No.	
4	Date of commencement of business	
5	PAN No. (Attach a copy)	
6	VAT/CST Clearance certificate (Attach a copy)	
7	Whether previous experience in the field (Attach proof)	
8	Warranty information.	Please attach list of items along with relevant warranty, if applicable
9	Product brochure/literature for each item	Attach copies of product brochure/literature for each item
10	Particulars of EMD attached	DDNo _____ Date _____ Amount <u>Rs. 50,000/-</u> Issuing Bank Name _____

**Signature of the Bidder with seal**



## FINANCIAL BID

To be filled & signed by the authorized signatory of the firm & this is to be put in separate sealed cover superscribed with “Financial bidfor furniture for VSSUT Halls of Residence”.

S/N	Item Description & Specifications	Rate	Quantity*	Total Price
1.	<b>Cots:</b> 1828mm (L)×914mm (W) made by 25mm × 5mm MS angle with four legs of 40 mm round MS steel hollow pipe fitted with 19mm commercial ply with provision for mosquito stand on the legs. The height of the cot shall be 457mm (H). Two numbers of 25mm angle intermediate support for the frame must be provided. The legs shall be strengthened by joining two legs with the help of 25mm round pipe on both the sides (Fig. 1). Cot should be properly primed red and then painted with oven backed painting with proper anti rust treatment. Rubber buffer must be fixed to four legs. All sides or joints must be welded properly (Joining various parts with nuts and bolts is not allowed).		<b>120</b>	
2.	<b>Study Table:</b> Study table of Size 914mm (L) × 610mm (W) × 762mm (H) made up of 18 gauge 1” size MS square pipe frame with 4 legs with PVC shoe and top periphery support bars and top with both side post form finish having 25mm MDF board with 1mm sunmica laminate of approved colour (Fig. 2). The MS frame should be properly primed red and then be painted with oven baked painting with proper anti-rust treatment. All sides or joints must be welded properly (Joining various parts with nuts and bolts is not allowed).		<b>300</b>	
3.	<b>Dining Table:</b> Dining Table of size 1800mm (L) × 914mm (W) × 750mm (H) made out of 16G stainless steel sheet.Frame of the dining table shall be made of SS square pipe of 25.4mm × 25.4mm ×1.5mm. 3 nos of square pipe of size 25.4mm × 25.4mm × 1.5 mm cross pipes to be provided in the frame for the top sheet support. 6 numbers of SS top stools with 25.4mm diameter seat and 1.5mm thickness to be provided and the stools to be attached permanently to the table. The legs for the table and the stools shall be of round SS pipe of 62mm diameter, 1.5mm thickness. 2 nos of SS		<b>30</b>	

	round pipe 25.4mm diameter, 1.50mm thickness shall be provided parallel to the length of the table for support. 3 nos. of cross bars made up of round SS pipe of size 62mm diameter and 1.5mm thickness to be provided joining the legs of the table and the stools. Rubber bush to be provided at the bottom of every leg (Fig. 3). There should be proper machining (shearing, bending etc.) and welding finish.			
4.	<b>Chair:</b> Moulded chair without arms of Neel Kamal/Supreme or equivalent make.		<b>400</b>	
<b>Taxes</b>				
<b>Grand Total (Inclusive of all taxes)</b>				

\* Approximate quantity. May vary at the time of placing order.

**Signature of the Bidder with seal**