

**SUB: Fundamentals of Fluid Mechanics**

Subject Code: BME 307

5<sup>th</sup> Semester, BTech

Prepared by

Arovinda Mohanty

Asst. Prof. Mechanical Engg. Dept

VSSUT Burla

## Disclaimer

This document does not claim any originality and cannot be used as a substitute for prescribed textbooks. The information presented here is merely a collection by the committee members for their respective teaching assignments. Various sources as mentioned at the reference of the document as well as freely available material from internet were consulted for preparing this document. The ownership of the information lies with the respective authors or institutions. Further, this document is not intended to be used for commercial purpose and the committee members are not accountable for any issues, legal or otherwise, arising out of use of this document. The committee members make no representations or warranties with respect to the accuracy or completeness of the contents of this document and specifically disclaim any implied warranties of merchantability or fitness for a particular purpose.

## SCOPE OF FLUID MECHANICS

Knowledge and understanding of the basic principles and concepts of fluid mechanics are essential to analyze any system in which a fluid is the working medium. The design of almost all means transportation requires application of fluid Mechanics. Air craft for subsonic and supersonic flight, ground effect machines, hovercraft, vertical takeoff and landing requiring minimum runway length, surface ships, submarines and automobiles requires the knowledge of fluid mechanics. In recent years automobile industries have given more importance to aerodynamic design. The collapse of the Tacoma Narrows Bridge in 1940 is evidence of the possible consequences of neglecting the basic principles fluid mechanics.

The design of all types of fluid machinery including pumps, fans, blowers, compressors and turbines clearly require knowledge of basic principles fluid mechanics. Other applications include design of lubricating systems, heating and ventilating of private homes, large office buildings, shopping malls and design of pipeline systems.

The list of applications of principles of fluid mechanics may include many more. The main point is that the fluid mechanics subject is not studied for pure academic interest but requires considerable academic interest.

## CHAPTER -1

### Definition of a fluid:-

Fluid mechanics deals with the behaviour of fluids at rest and in motion. It is logical to begin with a definition of fluid. Fluid is a substance that deforms continuously under the application of shear (tangential) stress no matter how small the stress may be. Alternatively, we may define a fluid as a substance that cannot sustain a shear stress when at rest.

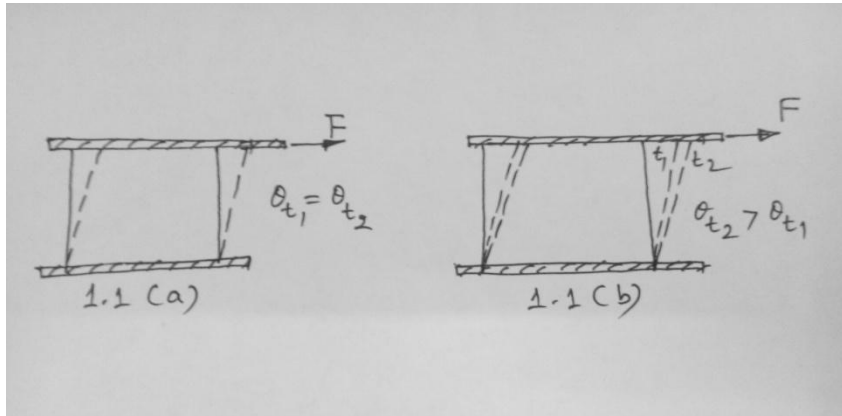

A solid deforms when a shear stress is applied, but its deformation doesn't continue to increase with time.

Fig 1.1(a) shows and 1.1(b) shows the deformation of solid and fluid under the action of constant shear force. The deformation in case of solid doesn't increase with time i.e  $\theta_{t1} = \theta_{t2} \dots \dots = \theta_{tn}$ .

From solid mechanics we know that the deformation is directly proportional to applied shear stress ( $\tau = F/A$ ), provided the elastic limit of the material is not exceeded.

To repeat the experiment with a fluid between the plates, let us use a dye marker to outline a fluid element. When the shear force 'F', is applied to the upper plate, the deformation of the fluid element continues to increase as long as the force is applied, i.e  $\theta_{t2} > \theta_{t1}$ .

### Fluid as a continuum :-

Fluids are composed of molecules. However, in most engineering applications we are interested in average or macroscopic effect of many molecules. It is the macroscopic effect that we ordinarily perceive and measure. We thus treat a fluid as infinitely divisible substance, i.e continuum and do not concern ourselves with the behaviour of individual molecules.

The concept of continuum is the basis of classical fluid mechanics. The continuum assumption is valid under normal conditions. However it breaks down whenever the mean free path of the molecules becomes the same order of magnitude as the smallest significant characteristic dimension of the problem. In the problems such as rarefied gas flow (as

# Fundamentals of Fluid Mechanics

encountered in flights into the upper reaches of the atmosphere ) , we must abandon the concept of a continuum in favour of microscopic and statistical point of view.

As a consequence of the continuum assumption, each fluid property is assumed to have a definite value at every point in the space .Thus fluid properties such as density , temperature , velocity and so on are considered to be continuous functions of position and time .

Consider a region of fluid as shown in fig 1.5. We are interested in determining the density at

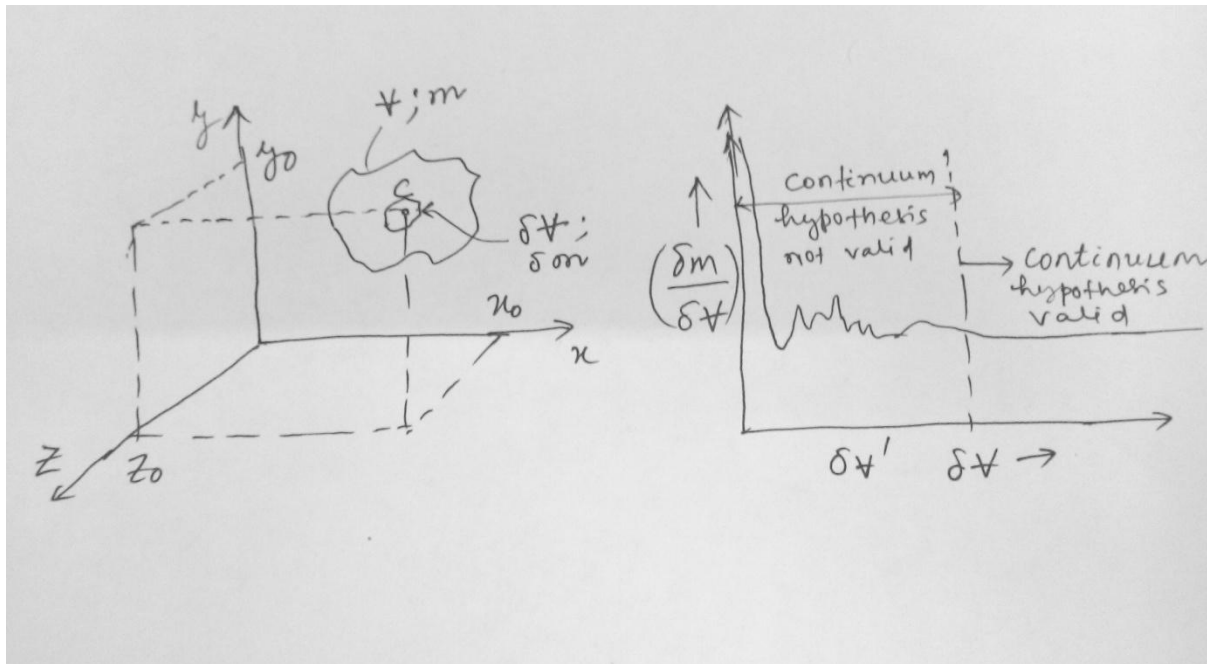

the point 'c', whose coordinates are  $x_0, y_0$  and  $z_0$  . Thus the mean density  $\bar{\rho}$  would be given by  $\bar{\rho} = \frac{m}{V}$  . In general, this will not be the value of the density at point 'c' . To determine the density at point 'c', we must select a small volume ,  $\delta V$ , surrounding point 'c' and determine the ratio  $\frac{\delta m}{\delta V}$  and allowing the volume to shrink continuously in size.

Assuming that volume  $\delta V$  is initially relatively larger (but still small compared with volume ,  $V$ ) a typical plot might appear as shown in fig 1.5 (b) . When  $\delta V$  becomes so small that it contains only a small number of molecules , it becomes impossible to fix a definite value for  $\frac{\delta m}{\delta V}$  ; the value will vary erratically as molecules cross into and out of the volume. Thus there is a lower limiting value of  $\delta V$ , designated  $\delta V'$  . The density at a point is thus defined as

$$\rho = \lim_{\delta V \rightarrow \delta V'} \frac{\delta m}{\delta V}$$

Since point 'c' was arbitrary, the density at any other point in the fluid could be determined in a like manner. If density determinations were made simultaneously at an infinite number of points in the fluid, we would obtain an expression for the density distribution as function of the space co-ordinates,  $\rho = \rho(x,y,z)$ , at the given instant.

Clearly, the density at a point may vary with time as a result of work done on or by the fluid and/or heat transfer to or from the fluid. Thus, the complete representation (the field representation) is given by:  $\rho = \rho(x,y,z,t)$

## Velocity field:

In a manner similar to the density, the velocity field; assuming fluid to be a continuum, can be expressed as:  $\vec{V} = \vec{V}(x,y,z,t)$

The velocity vector can be written in terms of its three scalar components, i.e

$$\vec{V} = u\hat{i} + v\hat{j} + w\hat{k}$$

In general;  $u = u(x,y,z,t)$ ,  $v = v(x,y,z,t)$  and  $w = w(x,y,z,t)$

If properties at any point in the flow field do not change with time, the flow is termed as steady. Mathematically, the definition of steady flow is  $\frac{\partial \eta}{\partial t} = 0$ ; where  $\eta$  represents any fluid property.

Thus for steady flow is  $\frac{\partial \rho}{\partial t} = 0$  or  $\rho = \rho(x,y,z)$

$$\frac{\partial \vec{V}}{\partial t} = 0 \text{ or } \vec{V} = \vec{V}(x,y,z)$$

Thus in steady flow, any property may vary from point to point in the field, but all properties, but all properties remain constant with time at every point.

## One, two and three dimensional flows :

A flow is classified as one two or three dimensional based on the number of space coordinates required to specify the velocity field. Although most flow fields are inherently three dimensional, analysis based on fewer dimensions are meaningful.

Consider for example the steady flow through a long pipe of constant cross section (refer Fig1.6a). Far from the entrance of the pipe the velocity distribution for a laminar flow can be described as:  $\frac{u}{u_{max}} = \left[1 - \left(\frac{r}{R}\right)^2\right]$ . The velocity field is a function of  $r$  only. It is independent of  $r$  and  $\theta$ . Thus the flow is one dimensional.

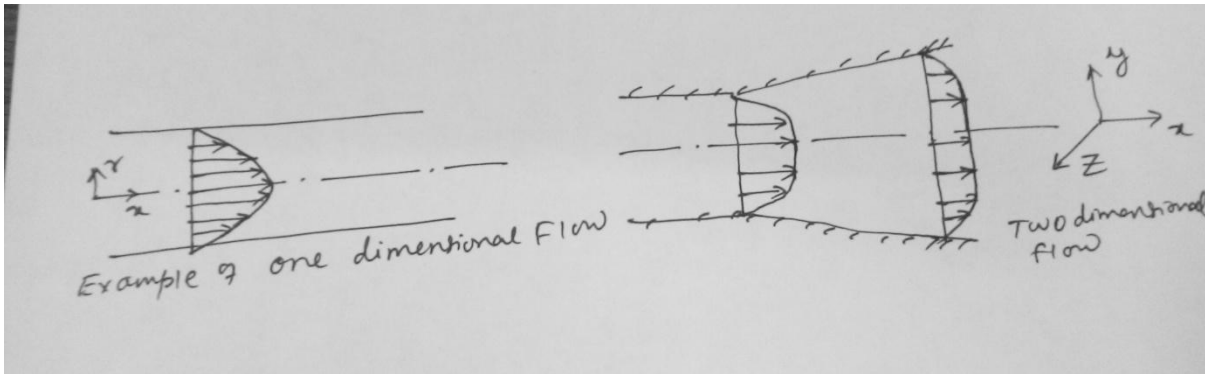
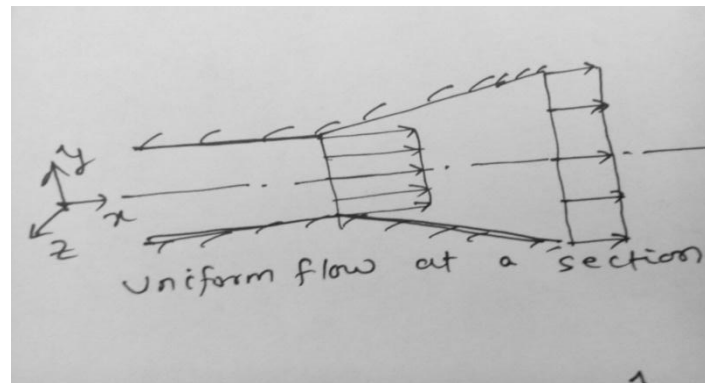

Fig1.6a and Fig1.6b

An example of a two-dimensional flow is illustrated in Fig1.6b. The velocity distribution is depicted for a flow between two diverging straight walls that are infinitely large in z direction. Since the channel is considered to be infinitely large in z the direction, the velocity will be identical in all planes perpendicular to z axis. Thus the velocity field will be only function of x and y and the flow can be classified as two dimensional. Fig 1.7

For the purpose of analysis often it is convenient to introduce the notion of uniform flow at a given cross-section. Under this situation the two dimensional flow of Fig 1.6 b is modelled as one dimensional flow as shown in Fig1.7, i.e. velocity field is a function of x only. However,



convenience alone does not justify the assumption such as a uniform flow assumption at a cross section, unless the results of acceptable accuracy are obtained.

**Stress Field:**

Surface and body forces are encountered in the study of continuum fluid mechanics. Surface forces act on the boundaries of a medium through direct contact. Forces developed without physical contact and distributed over the volume of the fluid, are termed as body forces . Gravitational and electromagnetic forces are examples of body forces .

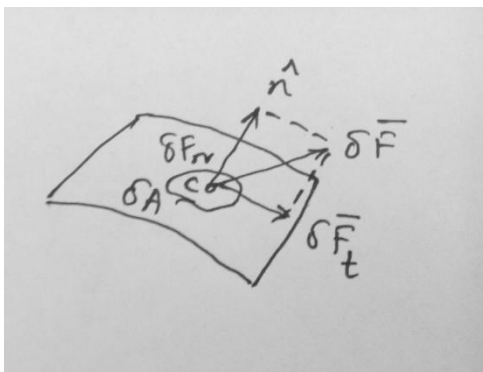

Consider an area  $\delta \bar{A}$  , that passes through 'c' .Consider a force  $\delta \bar{F}$  acting on an area  $\delta \bar{A}$  through point 'c' .The normal stress  $\sigma_n$  and shear stress  $\tau_n$  are then defined as :
$$\sigma_n = \lim_{\delta A_n \rightarrow 0} \frac{\delta F_n}{\delta A_n}$$

# Fundamentals of Fluid Mechanics

---

$\tau_n = \lim_{\delta A_n \rightarrow 0} \frac{\delta F_t}{\delta A_n}$ ; Subscript 'n' on the stress is included as a reminder that the stresses are associated with the surface  $\delta \bar{A}$ , through 'c', having an outward normal in  $\hat{n}$  direction. For any other surface through 'c' the values of stresses will be different.

Consider a rectangular co-ordinate system, where stresses act on planes whose normal are in x, y and z directions.

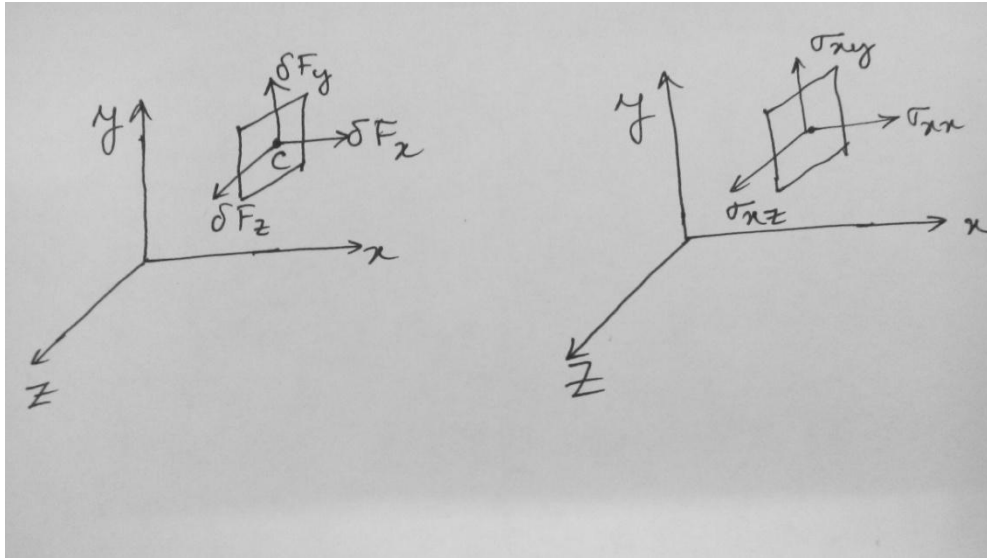

Fig 1.9

Fig 1.9 shows the forces components acting on the area  $\delta A_x$ .

The stress components are defined as ;

$$\sigma_{xx} = \lim_{\delta A_x \rightarrow 0} \frac{\delta F_x}{\delta A_x}$$

$$\sigma_{xy} = \lim_{\delta A_x \rightarrow 0} \frac{\delta F_y}{\delta A_x}$$

$$\sigma_{xz} = \lim_{\delta A_x \rightarrow 0} \frac{\delta F_z}{\delta A_x}$$

A double subscript notation is used to label the stresses. The first subscript indicates the plane on which the stress acts and the second subscript represents the direction in which the stress acts, i.e  $\sigma_{xy}$  represents a stress that acts on x- plane (i.e the normal to the plane is in x direction ) and acts in 'y' direction .

Consideration of area element  $\delta A_y$  would lead to the definition of the stresses ,  $\sigma_{yx}$  ,  $\sigma_{yy}$  and  $\sigma_{yz}$  . Use of an area element  $\delta A_z$  would similarly lead to the definition  $\sigma_{zx}$  ,  $\sigma_{zy}$  and  $\sigma_{zz}$  .



An infinite number of planes can be passed through point 'c', resulting in an infinite number of stresses associated with planes through that point. Fortunately, the state of stress at a point can be completely described by specifying the stresses acting on three mutually perpendicular planes through the point.

Thus, the stress at a point is specified by nine components and given by :

$$\bar{\sigma} = \begin{bmatrix} \sigma_{xx} & \sigma_{xy} & \sigma_{xz} \\ \sigma_{yx} & \sigma_{yy} & \sigma_{yz} \\ \sigma_{zx} & \sigma_{zy} & \sigma_{zz} \end{bmatrix}$$

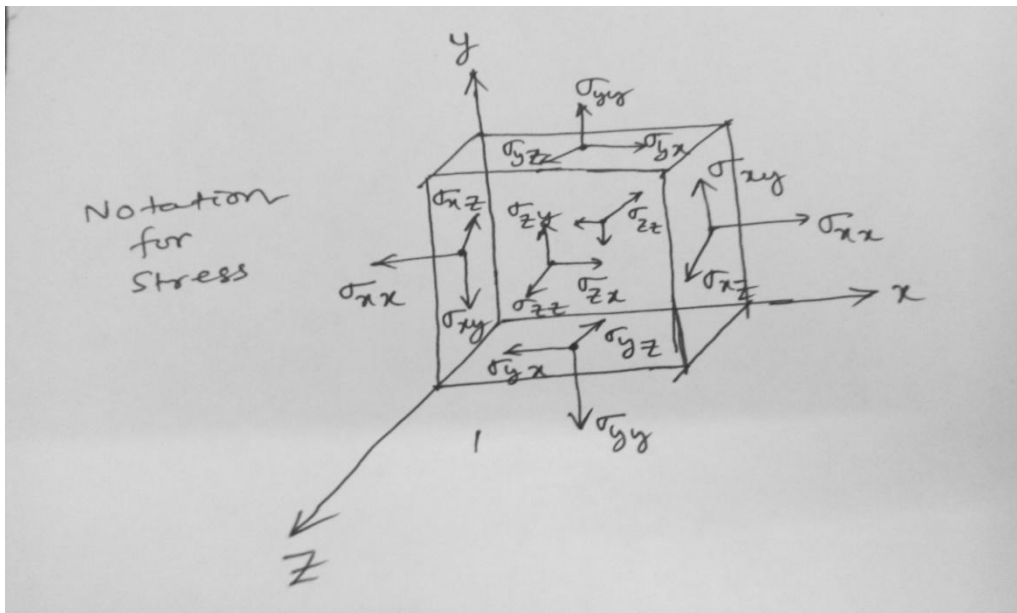

Fig 1.10

## Viscosity:

In the absence of a shear stress, there will be no deformation. Fluids may be broadly classified according to the relation between applied shear stress and rate of deformation.

Consider the behaviour of a fluid element between the two infinite plates shown in fig 1.11. The upper plate moves at constant velocity,  $\delta u$ , under the influence of a constant applied force,  $\delta F_x$ .

The shear stress,  $\sigma_{yx}$ , applied to the fluid element is given by :

$$\sigma_{yx} = \lim_{\delta A_y \rightarrow 0} \frac{\delta F_x}{\delta A_y} = \frac{dF_x}{dA_y}$$

Where,  $\delta A_y$  is the area of contact of a fluid element with the plate. During the interval  $\delta t$ , the fluid element is deformed from position MNOP to the position  $M'NOP'$ . The rate of deformation of the fluid element is given by:

# Fundamentals of Fluid Mechanics

---

$$\text{Deformation rate} = \lim_{\delta t \rightarrow 0} \frac{\delta \alpha}{\delta t} = \frac{d\alpha}{dt}$$

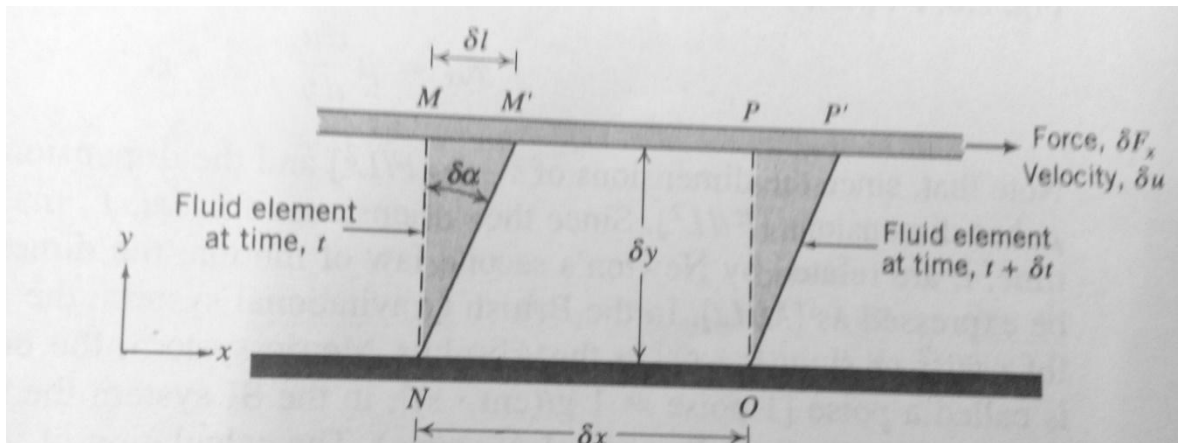

To calculate the shear stress,  $\sigma_{yx}$ , it is desirable to express  $\frac{d\alpha}{dt}$  in terms of readily measurable quantity.  $\delta l = \delta u \delta t$

Also for small angles,  $\delta l = \delta y \delta \alpha$

Equating these two expressions, we have

$$\frac{\delta \alpha}{\delta t} = \frac{\delta u}{\delta y}$$

Taking limit of both sides of the expression, we obtain;  $\frac{d\alpha}{dt} = \frac{du}{dy}$

Thus the fluid element when subjected to shear stress,  $\sigma_{yx}$ , experiences a deformation rate, given by  $\frac{du}{dy}$ .

# Fluids in which shear stress is directly proportional to the rate of deformation are "Newtonian fluids".

# The term Non-Newtonian is used to classify in which shear stress is not directly proportional to the rate of deformation.

## Newtonian Fluids :

Most common fluids i.e Air, water and gasoline are Newtonian fluids under normal conditions. Mathematically for Newtonian fluid we can write :

$$\sigma_{yx} \propto \frac{du}{dy}$$

If one considers the deformation of two different Newtonian fluids, say Glycerin and water, one recognizes that they will deform at different rates under the action of same applied stress. Glycerin exhibits much more resistance to deformation than water. Thus we say it is more viscous. The constant of proportionality is called, ' $\mu$ '.

Thus ,  $\sigma_{yx} = \mu \frac{du}{dy}$

## Non-Newtonian Fluids :

$\sigma_{yx} = k \left( \frac{du}{dy} \right)^n$  , 'n' is flow behaviour index and 'k' is consistency index .

To ensure that  $\sigma_{yx}$  has the same sign as that of  $\left( \frac{du}{dy} \right)$  , we can express

$$\sigma_{yx} = k \left| \left( \frac{du}{dy} \right) \right|^{n-1} \left( \frac{du}{dy} \right) = \eta \left( \frac{du}{dy} \right)$$

Where 'η' =  $k \left| \left( \frac{du}{dy} \right) \right|^{n-1}$  is referred as apparent viscosity.

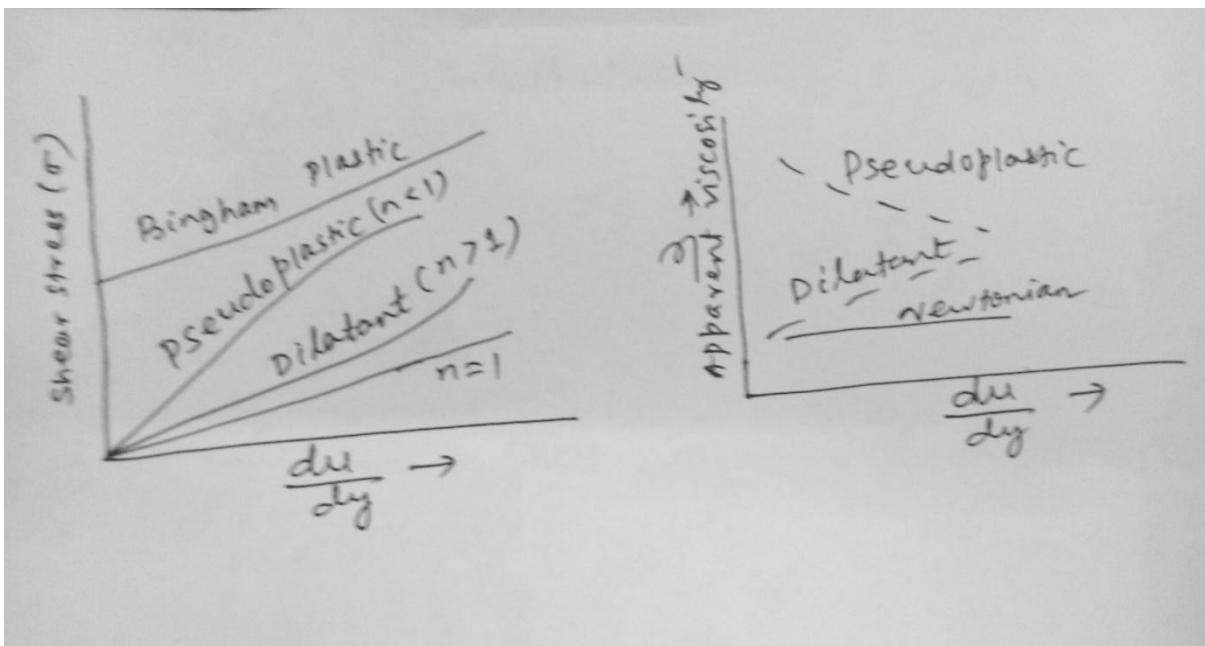

# The fluids in which the apparent viscosity decreases with increasing deformation rate ( $n < 1$ ) are called pseudoplastic (shear thinning) fluids . Most Non –Newtonian fluids fall into this category . Examples include : polymer solutions , colloidal suspensions and paper pulp in water.

# If the apparent viscosity increases with increasing deformation rate ( $n > 1$ ) the fluid is termed as dilatant( shear thickening). Suspension of starch and sand are examples of dilatant fluids .

# A fluid that behaves as a solid until a minimum yield stress is exceeded and subsequently exhibits a linear relation between stress and deformation rate .

$$\sigma_{yx} = \sigma_{yield} + \mu \left( \frac{du}{dy} \right)$$

Examples are : Clay suspension , drilling muds & tooth paste.

## Causes of Viscosity:

The causes of viscosity in a fluid are possibly due to two factors (i) intermolecular force of cohesion (ii) molecular momentum exchange.

#Due to strong cohesive forces between the molecules, any layer in a moving fluid tries to drag the adjacent layer to move with an equal speed and thus produces the effect of viscosity.

#The individual molecules of a fluid are continuously in motion and this motion makes a possible process of momentum exchange between layers. Such migration of molecules causes forces of acceleration or deceleration to drag the layers and produces the effect of viscosity.

Although the process of molecular momentum exchange occurs in liquids, the intermolecular cohesion is the dominant cause of viscosity in a liquid. Since cohesion decreases with increase in temperature, the liquid viscosity decreases with increase in temperature.

In gases the intermolecular cohesive forces are very small and the viscosity is dictated by molecular momentum exchange. As the random molecular motion increases with a rise in temperature, the viscosity also increases accordingly.

Example-1 An infinite plate is moved over a second plate on a layer of liquid. For small gap width  $d$ , a linear velocity distribution is assumed in the liquid. Determine :

- (i) The shear stress on the upper and lower plate .
- (ii) The directions of each shear stresses calculated in (i).

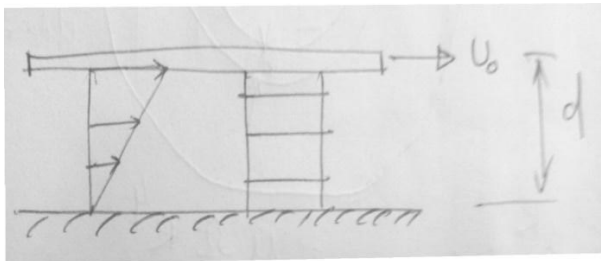

$$\text{Soln: } \tau_{yx} = \mu \frac{du}{dy}$$

Since the velocity profile is linear ;we have

$$\tau_{yx} = \mu \left( \frac{U_0 - 0}{d - 0} \right) = \mu \frac{U_0}{d}$$

$$\text{Hence; } \tau_{yx}|_{y=d} = \tau_{yx}|_{y=0} = \mu \frac{U_0}{d} = \text{constant}$$

## Example-2

An oil film of viscosity  $\mu$  & thickness  $h \ll R$  lies between a solid wall and a circular disc as shown in fig E .1.2. The disc is rotated steadily at an angular velocity  $\Omega$ . Noting that both the velocity and shear stress vary with radius 'r' , derive an expression for the torque 'T' required to rotate the disk.

Soln:

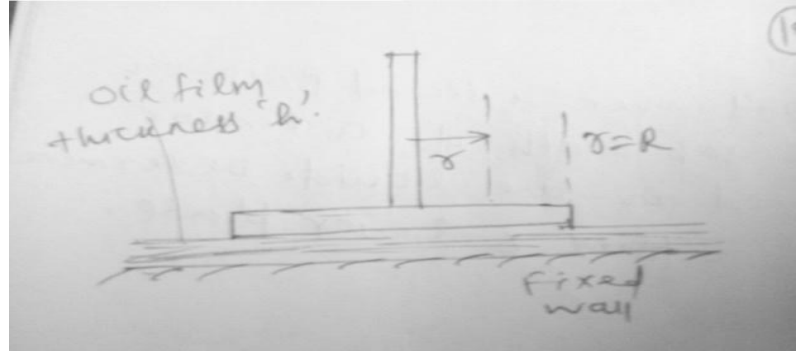

Assumption : linear velocity profile, laminar flow.  $u = \Omega r$ ;  $\tau_{yx} = \mu \frac{du}{dy} = \mu \frac{\Omega r}{h}$ ;  $dF = \tau dA$

$$dF = \mu \left( \frac{\Omega r}{h} \right) 2\pi r dr$$

$$T = \int dT = \int_0^R r dF = \frac{2\pi\mu\Omega}{h} \int_0^R r^3 dr = \frac{\pi\mu\Omega R^4}{2h}$$

## Vapor Pressure:

Vapor pressure of a liquid is the partial pressure of the vapour in contacts with the saturated liquid at a given temperature. When the pressure in a liquid is reduced to less than vapour pressure, the liquid may change phase suddenly and flash.

## Surface Tension:

Surface tension is the apparent interfacial tensile stress (force per unit length of interface) that acts whenever a liquid has a density interface, such as when the liquid contacts a gas, vapour, second liquid, or a solid. The liquid surface appears to act as stretched elastic membrane as seen by nearly spherical shapes of small droplets and soap bubbles. With some care it may be possible to place a needle on the water surface and find it supported by surface tension.

A force balance on a segment of interface shows that there is a pressure jump across the imagined elastic membrane whenever the interface is curved. For a water droplet in air, the pressure in the water is higher than ambient; the same is true for a gas bubble in liquid. Surface tension also leads to the phenomenon of capillary waves on a liquid surface and capillary rise or depression as shown in the figure below.

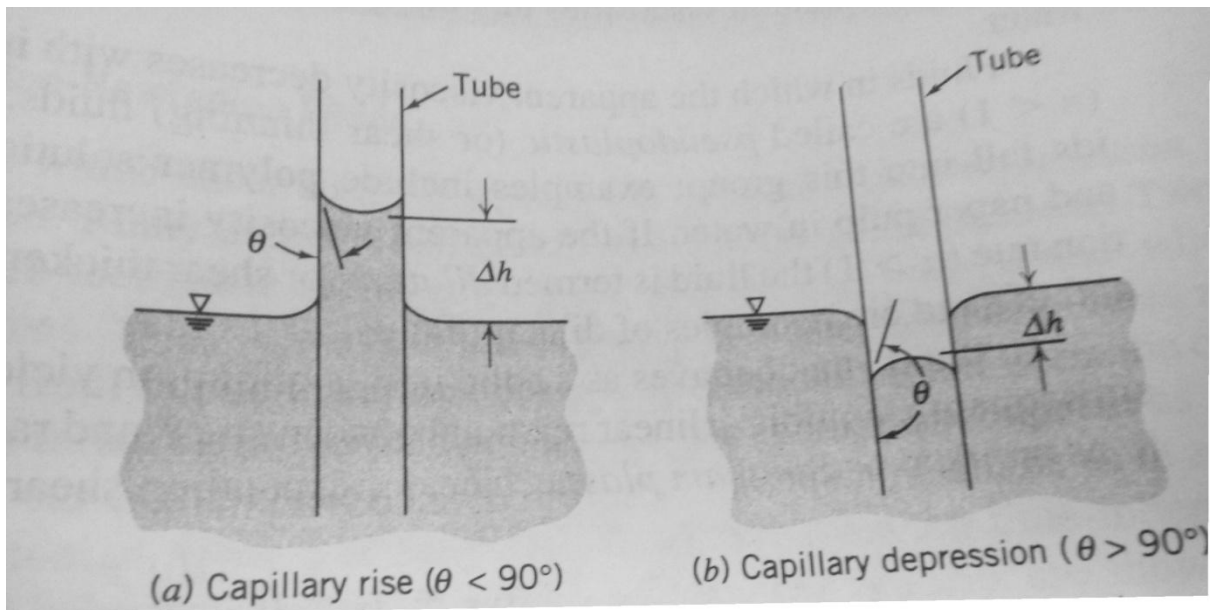

## Basic flow Analysis Techniques:

There are three basic ways to attack a fluid flow problem. They are equally important for a student learning the subject.

- (1) Control-volume or integral analysis
- (2) Infinitesimal system or differential analysis
- (3) Experimental or dimensional analysis.

In all cases the flow must satisfy three basic laws with a thermodynamic state relation and associated boundary condition.

1. Conservation of mass (Continuity)
2. Balance of momentum (Newton's 2<sup>nd</sup> law)
3. First law of thermodynamics (Conservation of energy)
4. A state relation like  $\rho = \rho(P, T)$
5. Appropriate boundary conditions at solid surface, interfaces, inlets and exits.

## Flow patterns:

Fluid mechanics is a highly visual subject. The pattern of flow can be visualized in a dozen of different ways. Four basic type of patterns are :

1. Stream line- A streamline is a line drawn in the flow field so that it is tangent to the line velocity field at a given instant.
2. Path line- Actual path traversed by a fluid particle.

# Fundamentals of Fluid Mechanics

3. Streak line- Streak line is the locus of the particles that have earlier passed through a prescribed point.

4. Time line – Time line is a set of fluid particles that form a line at a given instant .

For stream lines :  $d\vec{r} \times \vec{V} = 0$

$$\begin{vmatrix} i & j & k \\ dx & dy & dz \\ u & v & w \end{vmatrix} = 0$$

$$\Rightarrow \hat{i}(w dy - v dz) - \hat{j}(w dx - u dz) + \hat{k}(v dx - u dy) = 0$$

$$\Rightarrow w dy = v dz ; w dx = u dz \ \& \ v dx = u dy.$$

$$\text{So ; } \frac{dx}{u} = \frac{dy}{v} = \frac{dz}{w}$$

Ex: A velocity field given by  $\vec{V} = A x \hat{i} - A y \hat{j}$  .  $x, y$  are in meters . units of velocity in m/s.

$$A = 0.3 \text{ s}^{-1}$$

- obtain an equation for stream line in the  $x, y$  plane.
- Stream line plot through  $(2, 8, 0)$
- Velocity of a particle at a point  $(2, 8, 0)$
- Position at  $t = 6\text{s}$  of particle located at  $(2, 8, 0)$
- Velocity of particle at position found in (d)
- Equation of path line of particle located at  $(2, 8, 0)$  at  $t=0$

Soln:

(a) For stream lines ;  $\frac{dx}{u} = \frac{dy}{v}$

$$\Rightarrow \frac{dx}{Ax} = \frac{dy}{-Ay}$$

$$\Rightarrow \int \frac{dx}{x} = - \int \frac{dy}{y}$$

$$\Rightarrow \ln x = - \ln y + C$$

$$\Rightarrow \ln xy = C$$

$$\Rightarrow xy = C$$

(b) Stream line plot through  $(x_0, y_0, 0)$

$$\Rightarrow x_0 y_0 = C$$

$$\Rightarrow C = 16$$

$$\Rightarrow xy = 16$$

(c)  $\vec{V} = 0.6 \hat{i} - 0.6 \hat{j}$

(d)  $u = Ax$  ,  $\frac{dx}{dt} = Ax$  ,  $\int_{x_0}^x \frac{dx}{x} = A \int_0^t dt$

$$\Rightarrow \ln\left(\frac{x}{x_0}\right) = At$$
 ,  $\frac{x}{x_0} = e^{At}$

$v = -Ay$  ,  $\frac{dy}{dt} = -Ay$  ,  $\int_{y_0}^y \frac{dy}{y} = -A \int_0^t dt$

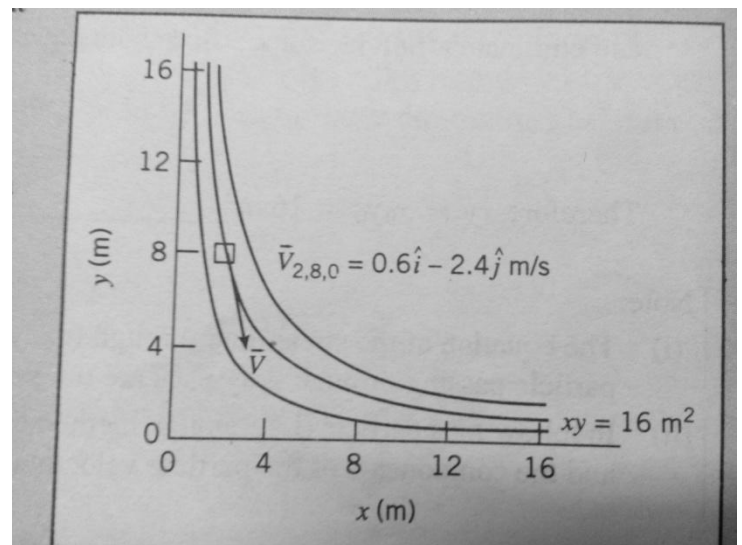

$$\Rightarrow \ln\left(\frac{y}{y_0}\right) = -At \quad , \quad \frac{y}{y_0} = e^{-At}$$

$$\text{At } t = 6\text{ s} ; x = 2 e^{0.3 \times 6} = 12.1 \text{ m}$$

$$; y = 8 e^{-0.3 \times 6} = 1.32 \text{ m}$$

$$(e) \vec{V} = 0.3 \times 12.1 \hat{i} - 0.3 \times 1.32 \hat{j} = 3.63 \hat{i} - 0.396 \hat{j}$$

(f) To determine the equation of the path line , we use the parametric equation :

$$x = x_0 e^{At} \quad \text{and} \quad y = y_0 e^{-At} \quad \text{and eliminate 't'}$$

$$\Rightarrow xy = x_0 y_0$$

Remarks :

(a) The equation of stream line through  $(x_0, y_0)$  and equation of the path line traced out by particle passing through  $(x_0, y_0)$  are same as the flow is steady.

(b) In following a particle ( Lagrangian method of description ) , both the coordinates of the particle  $(x, y)$  and the component  $(u_p \ \& \ v_p)$  are functions of time.

### Example -2:

A flow is described by velocity field,  $\vec{V} = ay \hat{i} + bt \hat{j}$  , where  $a = 1 \text{ s}^{-1}$  ,  $b = 0.5 \text{ m/s}^2$  . At  $t = 2\text{ s}$  , what are the coordinates of the particle that passed through  $(1, 2)$  at  $t = 0$  ? At  $t = 3\text{ s}$  , what are the coordinates of the particle that passed through the point  $(1, 2)$  at  $t = 2\text{ s}$  .

Plot the path line and streak line through point  $(1, 2)$  and compare with the stream lines through the same point  $(1, 2)$  at instant ,  $t = 0, 1, 2 \ \& \ 3 \text{ s}$  .

Soln:

Path line and streak line are based on parametric equations for a particle .

$$v = \frac{dy}{dt} = bt \quad , \quad \text{so,} \quad dy = bt \, dt$$

$$\Rightarrow y - y_0 = \frac{b}{2} (t^2 - t_0^2)$$

$$\& \ u = \frac{dx}{dt} = ay = a \left[ y_0 + \frac{b}{2} (t^2 - t_0^2) \right]$$

$$\Rightarrow \int_{x_0}^x dx = \int_{t_0}^t \left\{ a \left[ y_0 + \frac{b}{2} (t^2 - t_0^2) \right] \right\} dt$$

$$\Rightarrow (x - x_0) = a y_0 (t - t_0) + \frac{b}{2} \left( \frac{t^3}{3} - t_0^2 t \right)_{t_0}^t$$

$$\Rightarrow x = x_0 + a y_0 (t - t_0) + \frac{ab}{2} \left\{ \left( \frac{t^3 - t_0^3}{3} \right) - t_0^2 (t - t_0) \right\}$$

(a) For  $t_0 = 0$  and  $(x_0, y_0) = (1, 2)$  , at  $t = 2\text{ s}$  , we have

$$\Rightarrow y - 2 = \frac{b}{2} (4)$$

$$\Rightarrow y = 3 \text{ m}$$

$$\Rightarrow x = 1 + 2 (2 - 0) + \frac{0.5}{2} \left[ \frac{8}{3} - 0 \right] = 5.67 \text{ m}$$

(b) For  $t_0 = 2\text{ s}$  and  $(x_0, y_0) = (1, 2)$  . Thus at  $t = 3\text{ s}$



# Fundamentals of Fluid Mechanics

---

We have ,  $y - 2 = \frac{b}{2}(t^2 - t_0^2) = \frac{0.5}{2}(9-4) = 1.25$

$\Rightarrow y = 3.25 \text{ m}$

&  $x = 1 + 2(3-2) + \frac{0.5}{2} \left\{ \left( \frac{3^3-2^3}{3} \right) - 2^2(3-2) \right\}$

$\Rightarrow x = 1 + 2(3-2) + \frac{0.5}{2} \left\{ \left( \frac{27-8}{3} \right) - 4(1) \right\} = 3.58 \text{ m}$

(c) The streak line at any given 't' may be obtained by varying 't<sub>0</sub>' .

# part (a) : path line of particle located at (x<sub>0</sub> , y<sub>0</sub>) at t<sub>0</sub>= 0 s.

t <sub>0</sub> (s)	t	X(m)	Y(m)
0	0	1	2
0	1	3.08	2.25
0	2	5.67	3.00
0	3	9.25	4.25

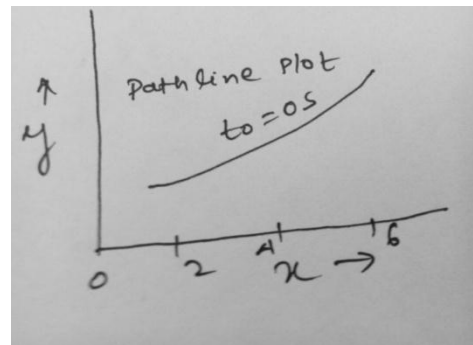

#part (b): path lines of a particle located at (x<sub>0</sub> , y<sub>0</sub>) at t<sub>0</sub> = 2s

t <sub>0</sub> (s)	t(s)	X	Y
2	2	1	2
2	3	3.58	3.25
2	4	7.67	5.0

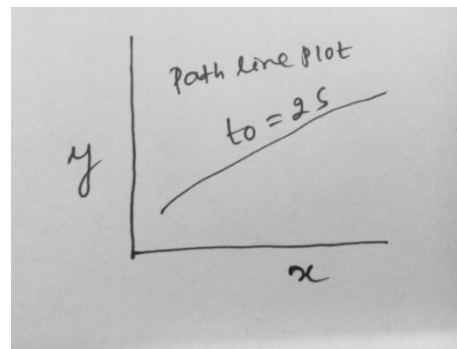

#part (c) :  $\frac{dx}{u} = \frac{dy}{v}$

$\Rightarrow dx = \left( \frac{ay}{bt} \right) dy$

$\Rightarrow y dy = \frac{bt}{a} dx$

$\Rightarrow y^2 = \left( \frac{2bt}{a} \right) x + c$

Thus ,  $c = y_0^2 - \left( \frac{2bt}{a} \right) x_0$

For (x<sub>0</sub> , y<sub>0</sub>) = (1,2) , for different value of 't' .

For t=0 ;  $c = (2)^2 = 4$

t = 1 ;  $c = 4 - \left( \frac{1}{1} \right) 1 = 3$

t = 2 ;  $c = 4 - \left( \frac{2}{1} \right) 1 = 2$

# Fundamentals of Fluid Mechanics

$$t=3; c = 4 - \left(\frac{3}{1}\right)1 = 1$$

t(s)	0	1	2	3
C=	4	3	2	1
X	Y	Y	Y	Y
1	2	2	2	2
2	2	2.24	2.45	2.65
3	2	2.45	2.83	3.16
4	2	2.65	3.16	3.61
5	2	2.53	3.46	4.0
6	2	3.0	3.74	4.36
7	2	3.16	4.00	4.69

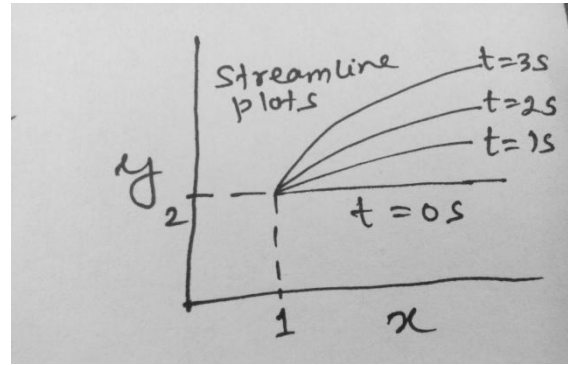

# Streak line of particles that passed through point  $(x_0, y_0)$  at  $t = 3s$ .

$t_0(s)$	$t(s)$	X(m)	Y(m)
0	3	9.25	4.25
1	3	6.67	4.00
2	3	3.58	3.25
3	3	1.0	2.0

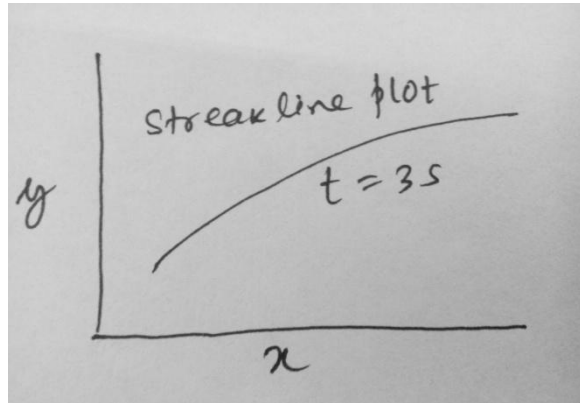

## CHAPTER – 2

### FLUID STATICS

In the previous chapter , we defined as well as demonstrated that fluid at rest cannot sustain shear stress , how small it may be. The same is true for fluids in “ rigid body” motion. Therefore, fluids either at rest or in “rigid body” motion are able to sustain only normal stresses. Analysis of hydrostatic cases is thus appreciably simpler than that for fluids undergoing angular deformation.

Mere simplicity doesn't justify our study of subject . Normal forces transmitted by fluids are important in many practical situations. Using the principles of hydrostatics we can compute forces on submerged objects, developed instruments for measuring pressure, forces developed by hydraulic systems in applications such as industrial press or automobile brakes.

In a static fluid or in a fluid undergoing rigid-body motion, a fluid particle retains its identity for all time and fluid elements do not deform. Thus we shall apply Newton's second law of motion to evaluate the forces acting on the particle.

#### The basic equations of fluid statics :

For a differential fluid element , the body force is  $d\bar{F}_B = \bar{g} \, dm = \bar{g} \, \rho \, d\forall$

(here , gravity is the only body force considered)where,  $\bar{g}$  is the local gravity vector , $\rho$  is the density &  $d\forall$  is the volume of the fluid element. In Cartesian coordinates,  $d\forall = dx \, dy \, dz$ . In a static fluid no shear stress can be present. Thus the only surface force is the pressure force. Pressure is a scalar field,  $p = p(x,y,z)$  ; the pressure varies with position within the fluid.

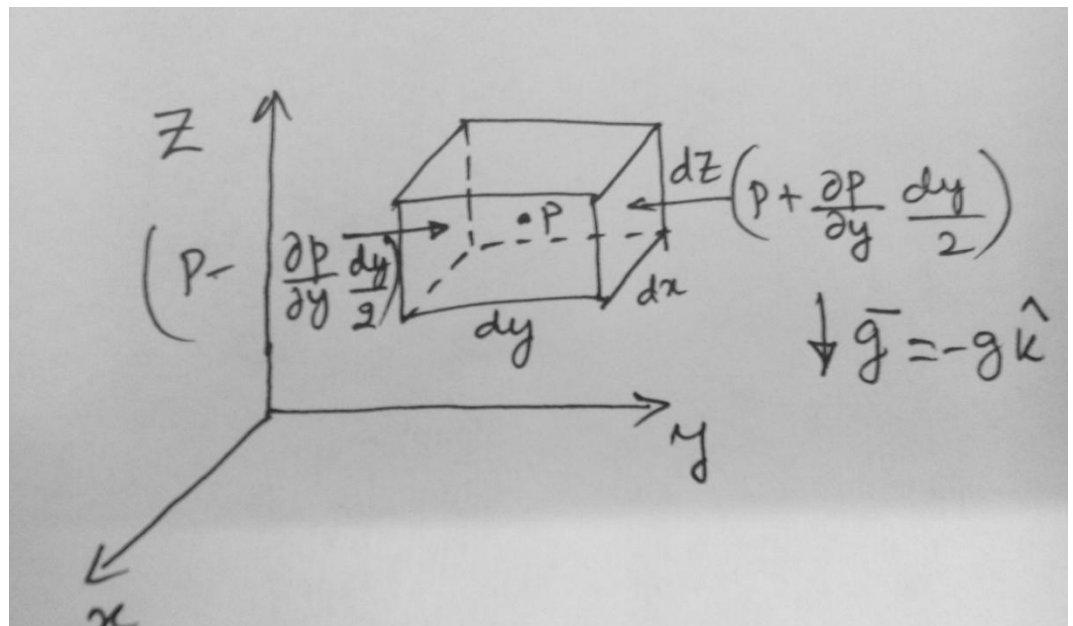

Pressure at the left face :  $P_L = ( p - \frac{\partial p}{\partial y} \frac{dy}{2} )$

Pressure at the right face :  $P_R = ( p + \frac{\partial p}{\partial y} \frac{dy}{2} )$

Pressure force at the left face :  $F_L = ( p - \frac{\partial p}{\partial y} \frac{dy}{2} ) dx dz \hat{j}$

Pressure force at the right face :  $F_R = ( p + \frac{\partial p}{\partial y} \frac{dy}{2} ) dx dz (-\hat{j})$

Similarly writing for all the surfaces , we have

$$d\vec{F}_s = \hat{i} ( p - \frac{\partial p}{\partial x} \frac{dx}{2} ) dy dz + ( p + \frac{\partial p}{\partial x} \frac{dx}{2} ) dy dz (-\hat{i}) + ( p - \frac{\partial p}{\partial y} \frac{dy}{2} ) dx dz \hat{j} \\ + ( p + \frac{\partial p}{\partial y} \frac{dy}{2} ) dx dz (-\hat{j}) + ( p + \frac{\partial p}{\partial z} \frac{dz}{2} ) dx dy (\hat{k}) + ( p - \frac{\partial p}{\partial z} \frac{dz}{2} ) dx dy (-\hat{k})$$

Collecting and concealing terms , we obtain :

$$d\vec{F}_s = - ( \hat{i} \frac{\partial p}{\partial x} + \hat{j} \frac{\partial p}{\partial y} + \hat{k} \frac{\partial p}{\partial z} ) dx dy dz$$

$$\triangleright d\vec{F}_s = - ( \nabla p ) dx dy dz$$

Thus

Net force acting on the body:

$$\triangleright d\vec{F} = d\vec{F}_s + d\vec{F}_B = ( - \nabla p + \rho \vec{g} ) dx dy dz$$

$$\triangleright d\vec{F} = ( - \nabla p + \rho \vec{g} ) d\forall$$

or, in a per unit volume basis:

$$\frac{d\vec{F}}{d\forall} = ( - \nabla p + \rho \vec{g} ) \quad \rightarrow (2.1)$$

For a fluid particle , Newton's second law can be expressed as :  $d\vec{F} = \vec{a} dm = \vec{a} \rho d\forall$

$$\text{Or } \frac{d\vec{F}}{d\forall} = \vec{a} \rho \quad \rightarrow (2.2)$$

Comparing 2.1 & 2.2 , we have

$$- \nabla p + \rho \vec{g} = \vec{a} \rho$$

For a static fluid ,  $\vec{a} = 0$  ; Thus we obtain ;  $- \nabla p + \rho \vec{g} = 0$

The component equations are ;

$$\vec{g} = -g \hat{k}$$

$$-\frac{\partial p}{\partial x} + \rho g_x = 0$$

$$g_x = 0 = g_y$$

# Fundamentals of Fluid Mechanics

$$-\frac{\partial p}{\partial y} + \rho g_y = 0$$

$$-\frac{\partial p}{\partial z} + \rho g_z = 0$$

Using the value of  $g_x, g_y$  &  $g_z$  we have

$$\frac{\partial p}{\partial x} = 0, \frac{\partial p}{\partial y} = 0 \quad \& \quad \frac{\partial p}{\partial z} = -\rho g \quad ; \text{ since } P=P(Z)$$

We can write  $\frac{dp}{dz} = -\rho g$

Restrictions: (i) Static fluid

(ii) gravity is the only body force

(iii) z axis is vertical upward

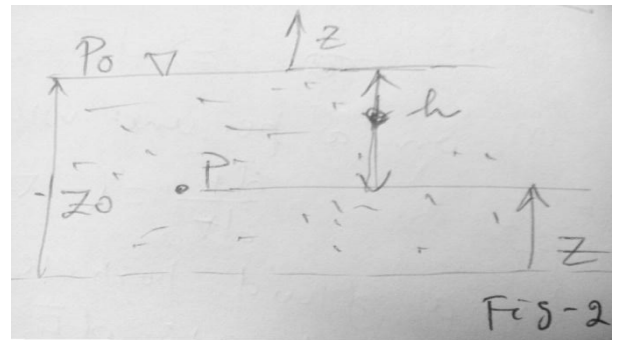
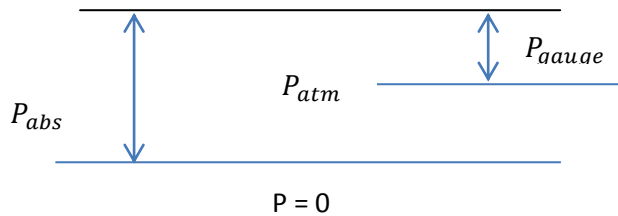

#Pressure variation in a static fluid :

$$\frac{dP}{dz} = -\rho g = \text{constant}$$

- $\int_{P_0}^P dP = -\rho g \int_{Z_0}^Z dZ$
- $P - P_0 = -\rho g(Z - Z_0)$
- $P - P_0 = -\rho g(Z_0 - Z) = \rho gh$

Ex:2.1 A tube of small diameter is dipped into a liquid in an open container. Obtain an expression for the change in the liquid level within the tube caused by the surface tension.

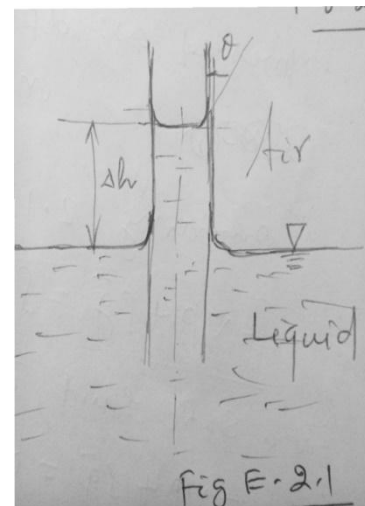
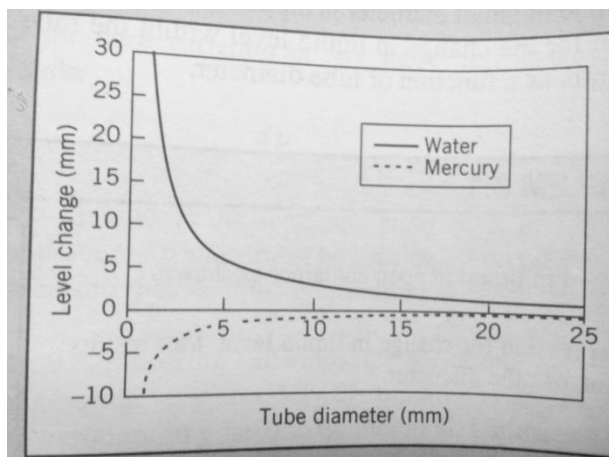

Soln:

$$\Sigma F_z = \sigma \pi D \cos \theta - \rho g \Delta \nabla = 0$$

Neglecting the volume of the liquid above  $\Delta h$ , we obtain

$$\Delta \nabla = \frac{\pi}{4} D^2 \Delta h$$

$$\text{Thus ; } \sigma \pi D \cos \theta - \rho g \frac{\pi}{4} D^2 \Delta h = 0$$

$$\Rightarrow \Delta h = \frac{4 \sigma \cos \theta}{\rho g D}$$

### Multi Fluid Manometer:

Ex2.2 Find the pressure at 'A'.

$$\text{Soln: } P_A + \rho_a g \times 0.15 - \rho_m g \times 0.15 + \rho_a g \times 0.15 - \rho_w g \times 0.3 = P_0$$

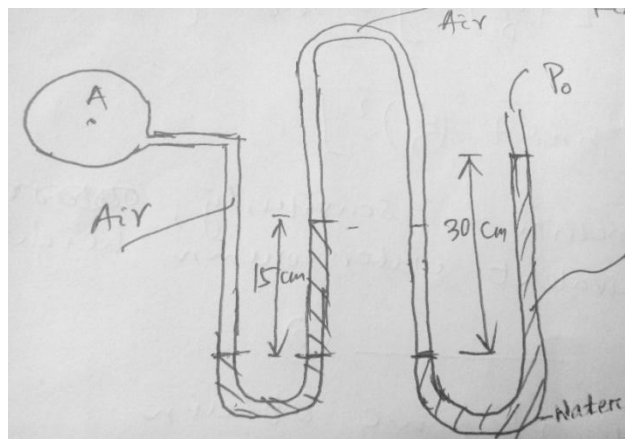

### #Inclined Tube manometer:

Ex2.3 Given : Inclined-tube reservoir manometer .

Find : Expression for 'L' in terms of  $\Delta P$ .

#General expression for manometer sensitivity

#parameter values that give maximum sensitivity

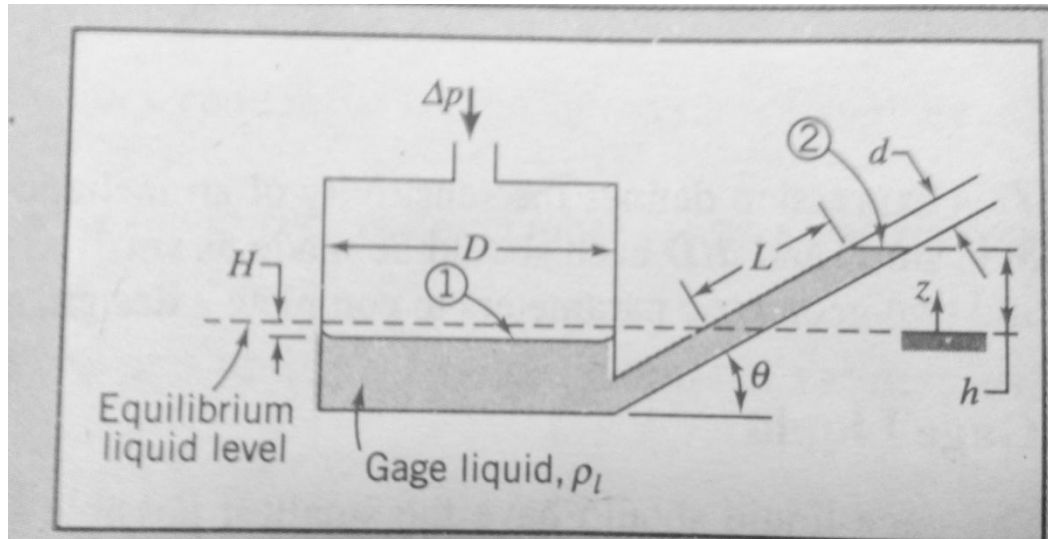

Soln:

Equating pressures on either side of Level -2 , we have;  $\Delta P = \rho_l g (h+H)$

To eliminate 'H' , we recognise that the volume of manometer liquid remains constant i.e the volume displaced from the reservoir must be equal to the volume rise in the tube.

$$\text{Thus ; } \frac{\pi}{4} D^2 H = \frac{\pi}{4} d^2 L$$

$$\text{➤ } H = L \left(\frac{d}{D}\right)^2$$

$$\text{➤ } \Delta P = \rho_l g \left[ L \sin\theta + L \left(\frac{d}{D}\right)^2 \right] = \rho_l g L \left[ \sin\theta + \left(\frac{d}{D}\right)^2 \right]$$

1

$$\text{Thus, } L = \frac{\Delta P}{\rho_l g \left[ \sin\theta + \left(\frac{d}{D}\right)^2 \right]}$$

To obtain an expression for sensitivity , express  $\Delta P$  in terms of an equivalent water column height ,  $h_e$

$$\Delta P = \rho_w g h_e$$

2

Combining equation 1 & 2 , we have

$$\rho_l g L \left[ \sin\theta + \left(\frac{d}{D}\right)^2 \right] = \rho_w g h_e$$

$$\text{Thus , } S = \frac{L}{h_e} = \frac{1}{SG \left[ \sin\theta + \left(\frac{d}{D}\right)^2 \right]}$$

$$\text{Where , } SG = \frac{\rho_e}{\rho_w}$$

The expression 'S' for sensitivity shows that to increase sensitivity SG ,  $\sin\theta$  and  $\frac{d}{D}$  should be made as small as possible.

## Hydrostatic Force on the plane surface which is inclined at an angle 'θ' to horizontal free surface:

We wish to determine the resultant hydrostatic force on the plane surface which is inclined at angle 'θ' to the horizontal free surface.

Since there can be no shear stresses in a static fluid, the hydrostatic force on any element of the surface must act normal to the surface. The pressure force acting on an element  $d\bar{A}$  of the upper surface is given by  $d\bar{F} = -p d\bar{A}$ .

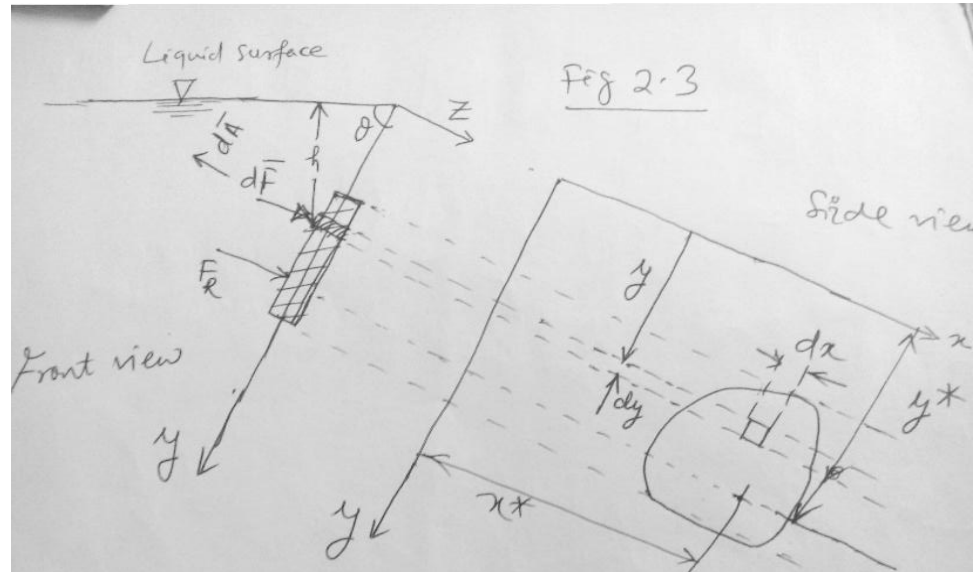

The negative sign indicates that the pressure force acts against the surface i.e in the direction opposite to the area  $d\bar{A}$ .  $\bar{F}_R = \int_A -pd\bar{A}$

If the free surface is at a pressure ( $P_0 = P_{atm}$ ), then,  $p = p_0 + \rho gh$

$$|\bar{F}_R| = \int_A (p_0 + \rho gh) dA = p_0 A + \int_A \rho g y \sin\theta dA$$

$$\rightarrow |\bar{F}_R| = p_0 A + \rho g \sin\theta \int_A y dA$$

$$\text{But } \int_A y dA = y_c A$$

$$\text{Thus, } |\bar{F}_R| = p_0 A + \rho g y_c A \sin\theta = (p_0 + \rho g y_c \sin\theta) A$$

Where  $h_c$  is the vertical distance between free surface and centroid of the area.

### # To evaluate the centre of pressure (c.p) or the point of application of the resultant force

The point of application of the resultant force must be such that the moment of the resultant force about any axis is equal to the sum of the moments of the distributed force about the same axis.

If  $\bar{r}^*$  is the position vector of centre pressure from the arbitrary origin, then

$$\bar{r}^* \times \bar{F}_R = \int \bar{r} \times d\bar{F} = - \int \bar{r} \times p d\bar{A}$$



Referring to fig 2.3 , we can express

$$\bar{r}^* = \hat{i} x^* + \hat{j} y^*$$

$$\bar{r} = x\hat{i} + y\hat{j} ; d\bar{A} = -dA \hat{k} \text{ and } \bar{F}_R = F_R \hat{k}$$

Substituting into equation , we obtain

$$(\hat{i} x^* + \hat{j} y^*) \times F_R \hat{k} = \int (x\hat{i} + y\hat{j}) \times d\bar{F} = \int_A (x\hat{i} + y\hat{j}) \times p dA \hat{k}$$

Evaluating the cross product , we get

$$\text{➤ } \hat{j} x^* F_R + \hat{i} y^* F_R = \int_A (-\hat{j} x p + \hat{i} y p) dA$$

Equating the components in each direction ,

$y^* F_R = \int_A y p dA$  and  $x^* F_R = \int_A x p dA$  #when the ambient (atmospheric) pressure ,  $p_0$  , acts on both sides of the surface , then  $p_0$  makes no contribution to the net hydrostatic force on the surface and it may be dropped . If the free surface is at a different pressure from the ambient, then ‘  $p_0'$  ’ should be stated as gauge pressure , while calculating the net force .

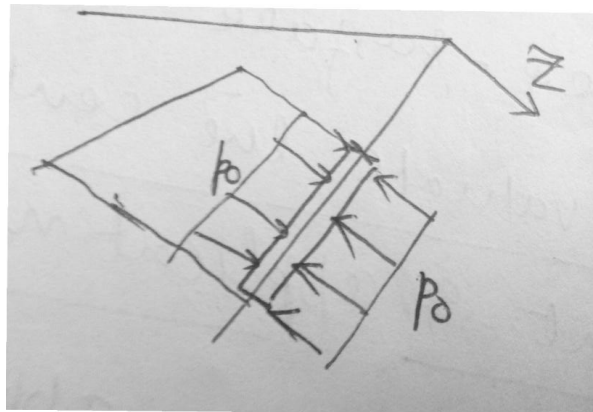

$$y^* = \frac{\int_A p y dA}{F_R} = \frac{\int_A \rho g x^2 \sin \theta dA}{\rho g y_c A \sin \theta}$$

$$\text{➤ } y^* = \frac{\rho g \sin \theta \int y^2 dA}{\rho g y_c A \sin \theta}$$

$$\text{➤ } y^* = \frac{I_{xx}}{A y_c}$$

But from parallel axis theorem ,  $I_{xx} = I_{\hat{x}\hat{x}} + A y_c^2$

Where  $I_{\hat{x}\hat{x}}$  is the second moment of the area about the centroidal ‘  $\hat{x}$  ’ axis . Thus

$$y^* = y_c + \frac{I_{\hat{x}\hat{x}}}{A y_c}$$

$$\text{Or , } y^* = \left( \frac{h_c}{\sin \theta} \right) + \frac{I_{\hat{x}\hat{x}} \sin \theta}{A h_c}$$

Similarly taking moment about ‘  $y$  ’ axis ;

$$x^* F_R = \int x p dA$$

$$\text{➤ } x^* \rho g \sin \theta y_c A = \int_A x \rho g h dA = \rho g \sin \theta \int_A x y dA$$

# Fundamentals of Fluid Mechanics

$$\triangleright x^* = \frac{\int_A xy dA}{Ay_c} = \frac{I_{xy}}{Ay_c}$$

From the parallel axis theorem ,  $I_{xx} = I_{\hat{x}\hat{y}} + Ax_c y_c$

Where  $I_{\hat{x}\hat{y}}$  is the area product of inertia w.r.t centroid al  $\hat{x}\hat{y}$  axis.

$$\text{So, } x^* = x_c + \frac{I_{\hat{x}\hat{y}}}{Ay_c}$$

For surface that is symmetric about 'y' axis ,  $x^* = x_c$  and hence usually not asked to evaluate.

### Example Problem:

Ex 2.4: Rectangular gate , hinged at 'A' ,  $w=5\text{m}$  . Find the resultant force ,  $\overline{F}_R$  , of the water and the air on the gate . The inclined surface shown , hinged along edge 'A' , is 5m wide . Determine the resultant force ,  $\overline{F}_R$  , of the water and air on the inclined surface.

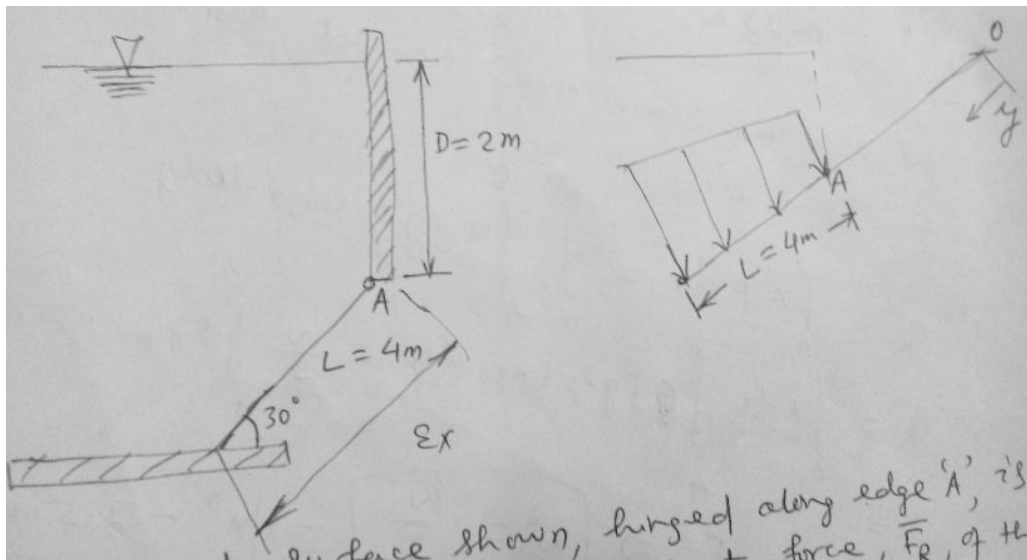

Soln:-

$$\overline{F}_R = \int_A p d\overline{A} = - \int_4^8 \rho g y \sin 30 w dy \hat{k}$$

$$\Rightarrow \overline{F}_R = -\frac{\rho g w}{2} \hat{k} \left[ \frac{y^2}{2} \right]_4^8 = -\frac{999 \times 9.81 \times 5}{4} [64-16] \hat{k}$$

$$\Rightarrow \overline{F}_R = -588.01 \text{ KN}$$

Force acts in negative 'z' direction.

### To find the line of action :

Taking moment about x axis through point 'O' on the free surface , we obtain :

$$y^* F_R = \int_A y p dA = \int_4^8 y \rho g \sin 30 w dy$$

# Fundamentals of Fluid Mechanics

- $y^* F_R = \left(\frac{\rho g w}{2}\right) \left[\frac{y^3}{3}\right]_4^8 = \frac{5 \times 999 \times 9.81}{6} [8^3 - 4^3]$
- $y^* \times (588.01 \times 10^3) = 3658.73 \times 10^3$
- $y^* = 6.22 \text{ m}$

#To find  $x^*$  ; we can take moment about y axis through point 'o'.

$$x^* F_R = \int_A x p dA = \int_0^w \int_4^8 x \rho y g \sin 30 dx dy$$

- $x^* F_R = \int_0^w x dx \int_4^8 \rho g y \sin 30 dy = \frac{w}{2} \int_4^8 \rho g y \sin 30 . w dy$
- $x^* F_R = \frac{w}{2} F_R$
- $x^* = \frac{w}{2} = 2.5 \text{ m}$

Alternative way: By directly using equations:

$$F_R = \rho g h_c A = \rho g (2 + 2 \sin 30) \times 4 \times 5$$

$$y^* = y_c + \frac{I_{xx}}{A y_c} = 6 + \frac{w l^3 / 12}{20 \times 6} = 6.22 \text{ m}$$

$$x^* = x_c + \frac{I_{xy}}{A y_c}$$

$$I_{xy} = \int_A \hat{x} \hat{y} dA = \int_{-\frac{w}{2}}^{\frac{w}{2}} \int_{-\frac{l}{2}}^{\frac{l}{2}} \hat{x} \hat{y} d\hat{x} d\hat{y} = 0$$

Thus ,  $x^* = x_c = 2.5 \text{ m}$

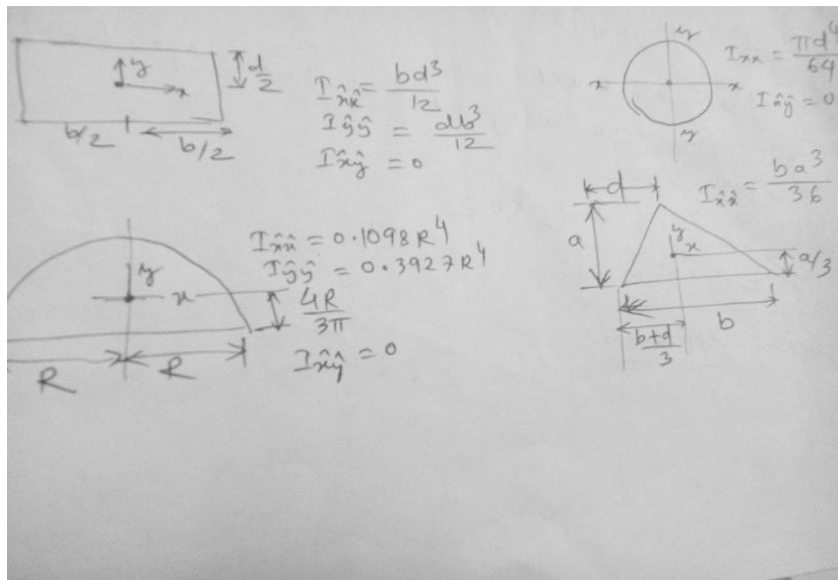

## Concept of pressure prism:

$$F_R = \text{volume} = \frac{1}{2} (\rho g h) h b$$

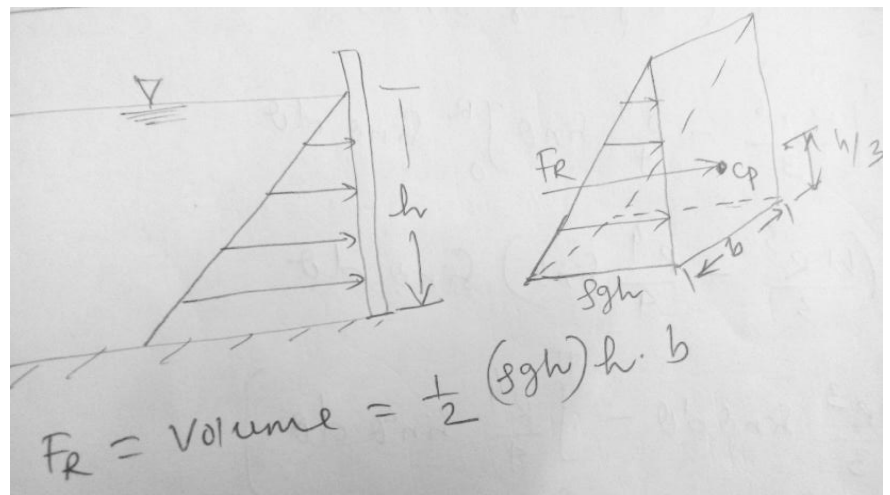

# Fundamentals of Fluid Mechanics

**Ex2.5:** A pressurised tank contains oil (SG=0.9) and has a square, 0.6 m by 0.6m plate bolted to its side as shown in fig. The pressure gage on the top of the tank reads 50kpa and the outside tank is at atmospheric pressure. Find the magnitude & location of the resultant force on the attached plate.

Soln :  $F_1 = (P_s + \rho g h_1) \times 0.36 = 24.4 \text{ kN}$

$F_2 = \frac{1}{2} \rho g (h_2 - h_1) \times 0.36 = 0.954 \text{ kN}$

$F_R = F_1 + F_2 = 25.4 \text{ kN}$

If ' $F_R$ ' is the force acting at a distance  $y^*$  for

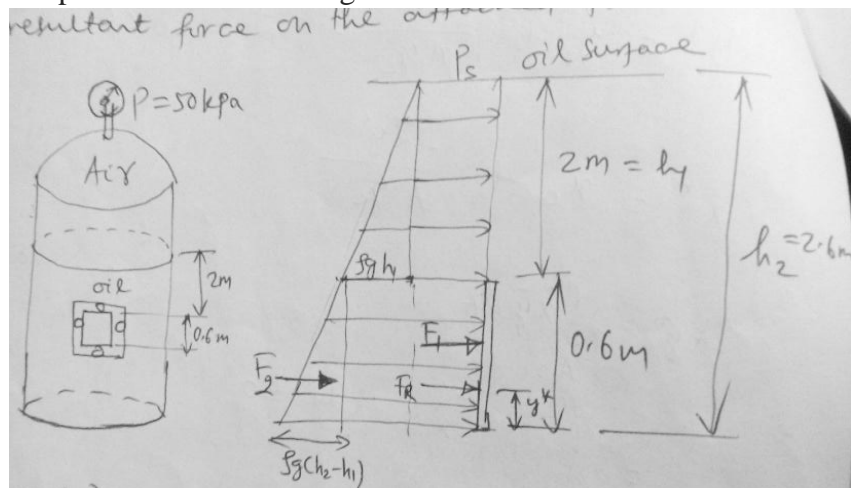

the bottom, we have ;  $F_R y^* = F_1 \times 0.3 + F_2 \times 0.2$  and  $y^* = 0.296 \text{ m}$

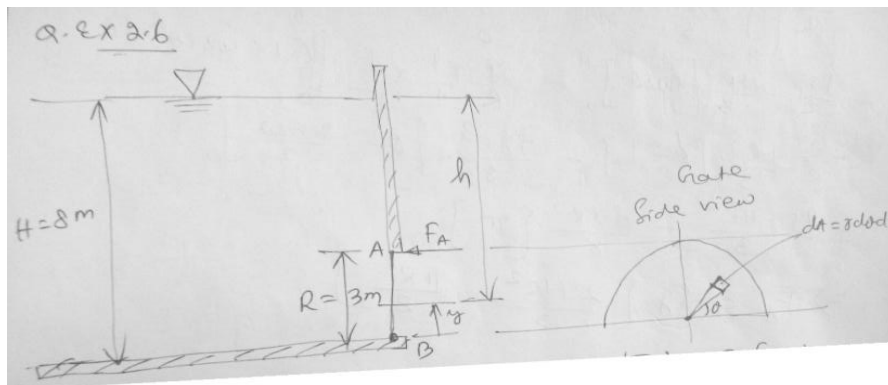

## Ex-2.6

Soln: Basic equations :

$\frac{dp}{dh} = \rho g ; |\overline{F_R}| = \int p dA ;$

$\sum \overline{M} = 0$ ; Taking moment about the hinge 'B', we have

$F_A R = \int y dF = \int \rho g h y dA$

- $dA = r d\theta dr ;$
- $y = r \sin\theta ; h = H - y$
- $F_A = \frac{1}{R} \int_0^\pi \int_0^R r \sin\theta \rho g (H - r \sin\theta) r dr d\theta$
- $F_A = \frac{\rho g}{R} \int_0^\pi \int_0^R (Hr^2 - r^3 \sin\theta) dr d\theta$

$$\begin{aligned}
 &= \frac{\rho g}{R} \int_0^\pi \left[ \frac{Hr^3}{3} - \frac{r^4}{4} \sin\theta \right]_0^R \sin\theta \, d\theta \\
 &= \frac{\rho g}{R} \int_0^\pi \left( \frac{HR^3}{3} - \frac{R^4}{4} \sin\theta \right) \sin\theta \, d\theta \\
 &= \frac{\rho g}{R} \left[ \int_0^\pi \frac{HR^3}{3} \sin\theta \, d\theta - \int_0^\pi \frac{R^4}{4} \sin^2\theta \, d\theta \right] \\
 &= \frac{\rho g}{R} \frac{HR^3}{3} [-\cos\theta]_0^\pi - \frac{\rho g}{R} \frac{R^4}{4} \times \frac{1}{2} \left[ \int_0^\pi (1 - \cos 2\theta) \, d\theta \right] \\
 &= -\frac{\rho g}{R} \frac{HR^3}{3} [-1-1] - \frac{\rho g R^3}{8} \left[ \theta - \frac{\sin 2\theta}{2} \right]_0^\pi \\
 &= \frac{2\rho g HR^2}{3} - \frac{\rho g R^3}{8} [\pi] \\
 &\quad \triangleright F_A = \rho g \left[ \frac{2HR^2}{3} - \frac{\pi R^3}{8} \right] \\
 &\quad \triangleright F_A = 366 \text{ kN} \quad . \quad (\text{Ans})
 \end{aligned}$$

Ex-2.7 :- Repeat the example problem 2.4 if the C.S area of the inclined surface is circular one , with radius R=2.

Soln: Using integration;

$$F_R = \int_A dF = \int_A \rho g h dA = \iint \rho g y \sin\theta \, dr \, rd\phi$$

$$\eta + y = 6m$$

$$\Rightarrow y = 6 - \eta = 6 - r \sin\phi$$

$$F_R = \rho g \sin 30 \int_0^{2\pi} \int_0^R (6 - r \sin\phi) r \, dr \, d\phi$$

$$= \frac{\rho g}{2} \int_0^{2\pi} \int_0^R (6r - r^2 \sin\phi) \, dr \, d\phi$$

$$\Rightarrow F_R = \frac{\rho g}{2} \int_0^{2\pi} \left[ \left( 6\frac{r^2}{2} - \frac{r^3}{3} \sin\phi \right) \right]_0^R \, d\phi = \frac{\rho g}{2} \int_0^{2\pi} \left( 3R^2 - \frac{R^3}{3} \sin\phi \right) \, d\phi$$

$$= \frac{\rho g}{2} \left[ 3R^2 \phi - \frac{R^3}{3} (-\cos\phi) \right]_0^{2\pi}$$

$$= \frac{\rho g}{2} [12 \times 2\pi - 0] = 12\rho g \pi = 369.458 \text{ kN}$$

Similarly for  $y^*$  we can write

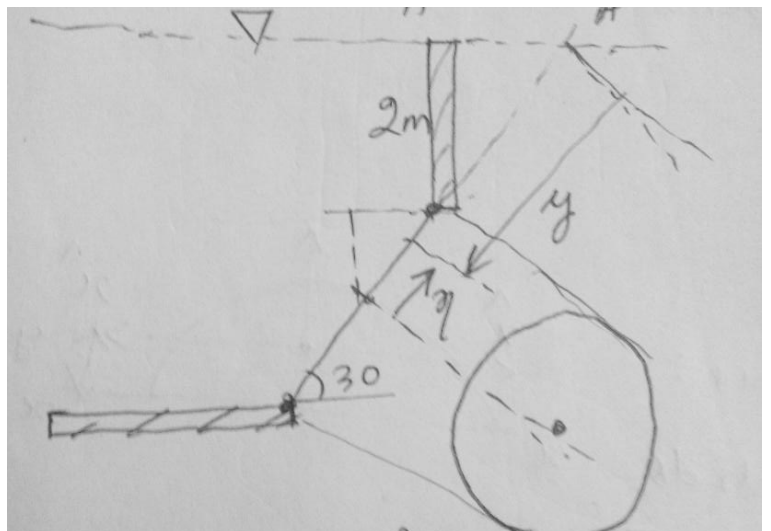

# Fundamentals of Fluid Mechanics

$$y^* \cdot F_R = \int y dF = \int_0^{2\pi} \int_0^R (6 - r \sin \phi)^2 \rho g \sin \theta dr r d\phi$$

By using formula :  $F_R = \rho g h_c A = \rho g (2 + 2 \sin 30) \pi R^2 = 369.458 \text{ kN}$

$$y^* = y_c + \frac{I_{\hat{x}\hat{x}}}{Ay_c} = 6 + \frac{\left(\frac{\pi R^4}{64}\right)}{\left(\frac{\pi R^2}{4}\right)} \times \frac{1}{6}$$

$$y^* = 6.166 \text{ m}$$

# Find  $I_{\hat{x}\hat{x}}$  for a circular C.S

$$dA = dr r d\phi$$

$$I_{\hat{z}\hat{z}} = \int r^2 dA = \int_0^{2\pi} \int_0^R r^3 dr d\phi$$

$$\Rightarrow I_{\hat{z}\hat{z}} = \frac{R^4}{4} \times 2\pi$$

But ,  $I_{\hat{x}\hat{x}} + I_{\hat{y}\hat{y}} = I_{\hat{z}\hat{z}}$  (perpendicular axis theorem)

$$\Rightarrow 2I_{\hat{x}\hat{x}} = \frac{2\pi R^4}{4}$$

$$\Rightarrow I_{\hat{x}\hat{x}} = \frac{\pi R^4}{4}$$

# Find  $I_{\hat{x}\hat{x}}$  for a semi-circle:

$$y_c = \frac{\int y dA}{\int dA} = \frac{\int_0^\pi \int_0^R r \sin \theta r dr d\theta}{\left(\frac{\pi R^2}{2}\right)}$$

$$= \frac{\left(\frac{R^3}{3}\right) [-\cos \theta]_0^\pi}{\left(\frac{\pi R^2}{2}\right)} = \frac{4R}{3\pi}$$

$$I_{xx} = \frac{\pi R^4}{8} \text{ (half of the circle)}$$

$$I_{xx} = I_{\hat{x}\hat{x}} + Ay_c^2$$

$$\Rightarrow \frac{\pi R^4}{8} = I_{\hat{x}\hat{x}} + \frac{\pi R^2}{2} \left(\frac{4R}{3\pi}\right)^2$$

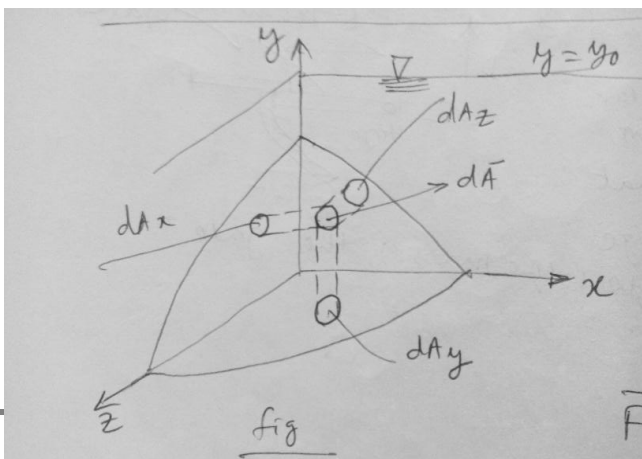
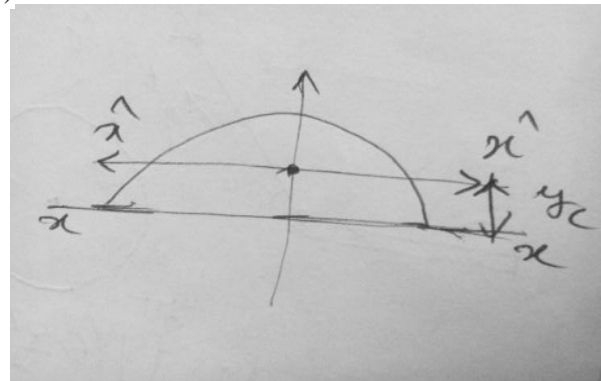
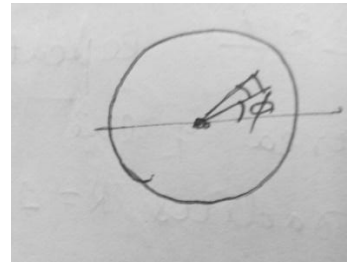

$$\Rightarrow I_{\hat{x}\hat{x}} = 0.1098 R^4$$

## #Hydrostatic Force on a curved submerged surface:

Consider the curved surface as shown in fig. The pressure force acting on the element of area,  $d\bar{A}$  is given by

$$d\bar{F} = -pd\bar{A}$$

$$\triangleright \bar{F} = - \int_A pd\bar{A}$$

We can write;  $\bar{F}_R = \hat{i}F_{Rx} + \hat{j}F_{Ry} + \hat{k}F_{Rz}$

Where,  $F_{Rx}, F_{Ry}$  &  $F_{Rz}$  are the components of  $\bar{F}_R$  in x, y & z directly respectively.

$$F_{Rz} = \hat{k} \bar{F}_R = \int d\bar{F} \cdot \hat{k} = - \int_A pd\bar{A} \hat{k} = - \int_{A_z} pdA_z$$

Since the direction of the force component can be found by inspection, the use of vectors is not necessary.

Thus we can write:  $F_{Rl} = \int_{A_l} pdA_l$

Where  $dA_l$  is the projection of the element  $dA$  on a plane perpendicular to the 'l' direction.

With the free surface at atmospheric pressure, the vertical component of the resultant hydrostatic force on a curved submerged surface is equal to the total weight of the liquid above the surface.

$$F_{Ry} = \int pdA_y = \int \rho gh dA_y = \int \rho g dV = \rho g \nabla$$

Ex:2.9: The gate shown is hinged at 'O' and has a constant width  $w = 5\text{ m}$ . The equation of the surface is  $x = \frac{y^2}{a}$ , where  $a = 4\text{ m}$ . The depth of water to the right of the gate is  $D = 4\text{ m}$ . Find

the magnitude of the force,  $F_a$ , applied as shown, required to maintain the gate in equilibrium if the weight of the gate is neglected.

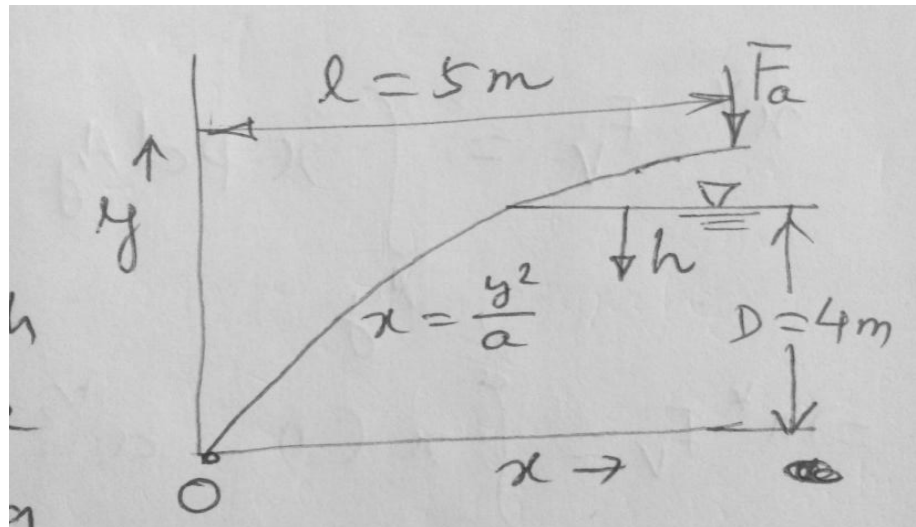

Soln: Horizontal Component of force:-

$$F_{RH} = \rho g h_c (WD) = \rho g (0.5) WD = 392 \text{ kN} \cdot h^*$$

$$h^* = h_c + \frac{I_{\hat{x}\hat{x}}}{Ay_c} = 0.5D + \frac{\left(\frac{wD^3}{12}\right)}{\left(wD \times \frac{D}{2}\right)}$$

$$= 0.5D + \frac{D}{6} = 2.67 \text{ m}$$

Vertical component:

$$F_v = \int_0^{\frac{D^2}{a}} p w dx = \int_0^{\frac{D^2}{a}} \rho g h w dx = \rho g w \int_0^{\frac{D^2}{a}} h dx$$

$$\rightarrow F_v = \rho g w \int_0^{\frac{D^2}{a}} \left(D - a^{\frac{1}{2}} x^{\frac{1}{2}}\right) dx \quad , \text{ (where } h+y=D, h = D-y = D-(ax)^{1/2} \text{ )}$$

$$\rightarrow F_v = \rho g w \left[ Dx - a^{\frac{1}{2}} \frac{2}{3} x^{\frac{3}{2}} \right]_0^{\frac{D^2}{a}} = (\rho g w D^3 / 3a)$$

$$\rightarrow F_v = 261 \text{ kN}$$

$$x^* F_v = \int_{A_y} x p dA_y = \int_0^{\frac{D^2}{a}} x \rho g h w dx$$

$$\rightarrow x^* F_v = \int_0^{\frac{D^2}{a}} x \left(D - a^{\frac{1}{2}} x^{\frac{1}{2}}\right) dx = \frac{\rho g w D^5}{10 a^2}$$

$$\rightarrow x^* = \frac{1}{F_v} \left(\frac{\rho g w D^5}{10 a^2}\right) = 1.2 \text{ m}$$

Summing moments about 'O'

$$\sum M_0 = x^* F_v + F_H(D - h^*) - l F_a = 0$$

$$\Rightarrow F_a = 167 \text{ kN.}$$



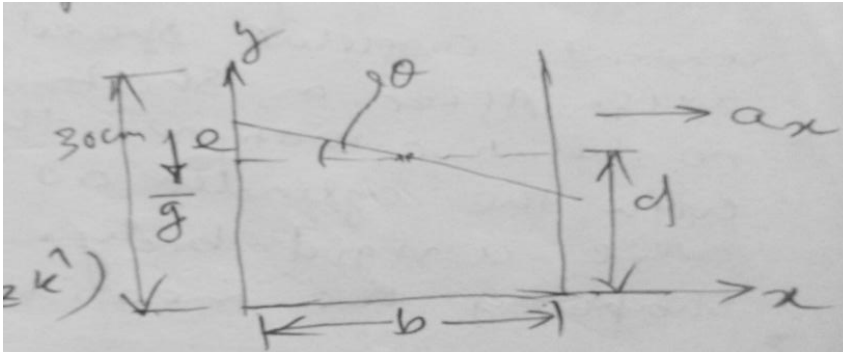

## Fluids in Rigid-Body Motion:-

Basic equation:  $-\nabla p + \rho \bar{g} = \rho \bar{a}$

A fish tank 30cm×60cm×30cm is partially filled with water to be transported in an automobile. Find allowable depth of water for reasonable assurance that it will not spill during the trip.

Soln:  $b=d=30\text{cm}=0.3\text{m}$

$$-\left(\frac{\partial p}{\partial x} \hat{i} + \frac{\partial p}{\partial y} \hat{j} + \frac{\partial p}{\partial z} \hat{k}\right) + \rho (\hat{i}g_x + \hat{j}g_y + \hat{k}g_z) = \rho (\hat{i}a_x + \hat{i}a_y + \hat{i}a_z)$$

But;  $g_x = 0 = g_z$  &  $a_x = 0 = a_z$

$$\Rightarrow \frac{\partial p}{\partial z} = 0$$

$$\Rightarrow p = p(x, y)$$

$$-\frac{\partial p}{\partial x} = \rho a_x$$

$$-\frac{\partial p}{\partial y} = \rho g \quad (g_y = -g) \quad \bar{g} = -g\hat{j}$$

Now we have to find an expression for  $p(x, y)$ .

$$dp = \frac{\partial p}{\partial x} dx + \frac{\partial p}{\partial y} dy$$

But since the free surface is at constant pressure, we have to;

$$0 = \frac{\partial p}{\partial x} dx + \frac{\partial p}{\partial y} dy$$

$$\Rightarrow \left(\frac{dy}{dx}\right)_{\text{surface}} = -\frac{a_x}{g} \quad (\text{the free surface is a plane})$$

$$\Rightarrow \tan\theta = \frac{(b/2)}{e} = \frac{b}{2} \left(\frac{a_x}{g}\right)$$

$$\Rightarrow e = \frac{b}{2} \left(\frac{a_x}{g}\right) = 0.15 \left(\frac{a_x}{g}\right) \quad \{\text{as } b=0.3\text{m}\}$$

The minimum allowable value of 'e' = (0.3 - d)m

Thus;  $0.3 - d = 0.15 \left(\frac{a_x}{g}\right)$

Hence ,  $d_{max} = 0.3 - 0.15 \left(\frac{a_x}{g}\right)$

### #Liquid in rigid body motion with constant angular speed:

A cylindrical container , partially filled with liquid , is rotated at a constant angular speed ,  $\omega$ , about its axis. After a short time there is no relative motion; the liquid rotates with the cylinder as if the system were a rigid body .Determine the shape of the free surface.

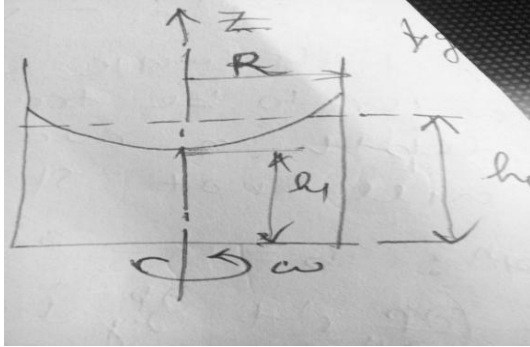

Soln: In cylindrical co-ordinate;

$$\nabla p = e_r \frac{\partial p}{\partial r} + \frac{e_\theta}{r} \frac{\partial p}{\partial \theta} + e_z \frac{\partial p}{\partial z}$$

$$\& -\nabla p + \rho g = \rho \bar{a}$$

$$-(e_r \frac{\partial p}{\partial r} + \frac{e_\theta}{r} \frac{\partial p}{\partial \theta} + e_z \frac{\partial p}{\partial z}) + \rho(e_r g_r + e_\theta g_\theta + e_z g_z) = \rho(e_r a_r + e_\theta a_\theta + e_z a_z)$$

For the given problem ;  $g_r = g_\theta = 0$  &  $g_z = -g$

and  $a_\theta = a_z = 0$  and  $a_r = -\omega^2 r$

The component equations are:

$$\frac{\partial p}{\partial r} = \rho \omega^2 r ; \frac{\partial p}{\partial \theta} = 0 \text{ and } \frac{\partial p}{\partial z} = -\rho g$$

Hence ,  $p(r,z)$  only

$$dp = \frac{\partial p}{\partial r} \Big|_z dr + \frac{\partial p}{\partial z} \Big|_r dz$$

Taking  $(r_1, z_1)$  as reference point , where the pressure is  $p_1$  and the arbitrary point  $(r,z)$  where the pressure is  $p$ , we can obtain the pressure difference as ;

$$\int_{p_1}^p dp = \int_{r_1}^r \frac{\partial p}{\partial r} dr + \int \frac{\partial p}{\partial z} dz$$

$$\Rightarrow p - p_1 = \rho \frac{\omega^2}{2} (r^2 - r_1^2) - \rho g(z - z_1)$$

If we take the reference point at the free surface on the cylinder axis , then;

$$p_1 = p_{atm} ; r_1 = 0 \text{ and } z_1 = h_1$$

$$p - p_{atm} = \rho \frac{\omega^2}{2} r^2 - \rho g(z - h_1)$$

Since the free surface is a surface of constant pressure ( $p = p_{atm}$ ) , the equation of the free surface is given by :

$$0 = \rho \frac{\omega^2}{2} r^2 - \rho g(z - h_1)$$

$$\Leftrightarrow z = h_1 + \frac{\omega^2}{2g} r^2 = h_1 + \frac{(r\omega)^2}{2g}$$

Volume of the liquid remain constant . Hence  $\forall = \Pi R^2 h_0$  ( without rotation)

With rotation :

$$\forall = \int_0^R \int_0^z 2\pi r (h_1 + \frac{\omega^2}{2g} r^2) r . dr$$

$$\Leftrightarrow \forall = \pi [ h_1 R^2 + \frac{\omega^2 R^4}{4g} ]$$

$$\text{and } h_1 = h_0 - \frac{\omega^2 R^2}{4g}$$

$$\text{Finally: } z = h_0 - \frac{(r\omega)^2}{2g} [ \frac{1}{2} - (\frac{r}{R})^2 ]$$

Note that this expression is valid only for  $h_1 > 0$  . Hence the maximum value of  $\omega$  is given by

$$\omega_{max} = \frac{[2gh_0]^{1/2}}{R} .$$

$$\{ (\omega R)^2 = (h_0 - h_1) \times 4g \text{ and } \omega^2 = \frac{1}{R^2} (h_0 - h_1) \times 4g$$

$$\text{For } , \omega_{max} ; h_1 \cong 0 \}$$

## Buoyancy:

When a stationary body is completely submerged in a fluid or partially immersed in a fluid, the resultant fluid force acting on the body is called the ‘Buoyancy’ force. Consider a solid body of arbitrary shape completely submerged in a homogeneous liquid.

$$d\bar{F}_1 = p d\bar{A}$$

$$dF_{V1} = (p_{atm} + p_1) dA_z = (p_{atm} + \rho g h_1) dA_z$$

$$dF_{V2} = (p_{atm} + p_2) dA_z = (p_{atm} + \rho g h_2) dA_z$$

The buoyant force (the net force acting vertically upward) acting on the elemental prism is

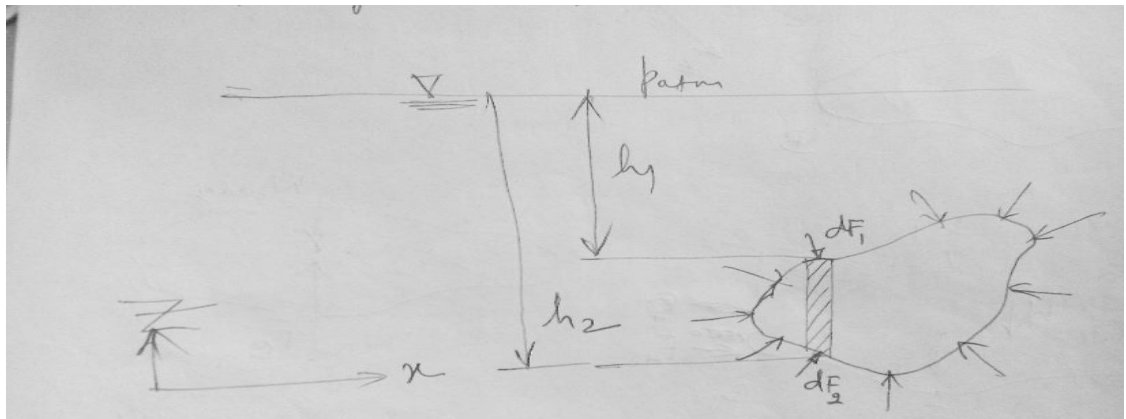

$$dF_B = (dF_{V2} - dF_{V1}) = \rho g (h_2 - h_1) dA_z = \rho g d\forall$$

Where,  $d\forall$  = volume of the prism

Hence, the buoyant force  $F_B$  on the entire submerged body is obtained as :

$$F_B = \int_V \rho g d\forall, \quad \text{i.e } F_B = \rho g \forall$$

Consider a body of arbitrary shape, having a volume  $\forall$ , is immersed in a fluid. We enclose the body in a parallelepiped and draw a free body diagram of the parallelepiped with the body removed as shown in fig. The forces  $F_1, F_2, F_3$  &  $F_4$  are simply the forces acting on the parallelepiped,  $w_f$  is the weight of the fluid volume (dotted region);  $F_B$  is the force the body is exerting on the fluid.

### Alternate approach:-

The forces on vertical surfaces are equal and opposite in direction and cancel,

$$\text{i.e } F_3 - F_4 = 0.$$

$$F_1 + F_B + w_f = F_2 \quad \text{or } F_B = F_2 - F_1 - w_f$$

$$\text{Also; } F_1 = \rho_f g h_1 A, \quad F_2 = \rho_f g h_2 A \quad \text{and } w_f = \rho_f g [A(h_2 - h_1) - \forall]$$

## Fundamentals of Fluid Mechanics

---

- $F_B = \rho_f g h_2 A - \rho_f g h_1 A - \rho_f g [A(h_2 - h_1) - \nabla]$
- $F_B = \rho_f g \nabla$ , where  $\nabla$  is volume of the body

The direction of the buoyant force, which is the force of the fluid on the body, will be opposite to that of ' $F_B$ ' shown in fig (FBD of fluid). Therefore, the buoyant force has a magnitude equal to the weight of the fluid displaced by the body and is directed vertically upward. The line of action of the buoyant force can be determined by summing moments of the forces w.r.t some convenient axis. Summing the moments about an axis perpendicular to paper through point 'A' we have:

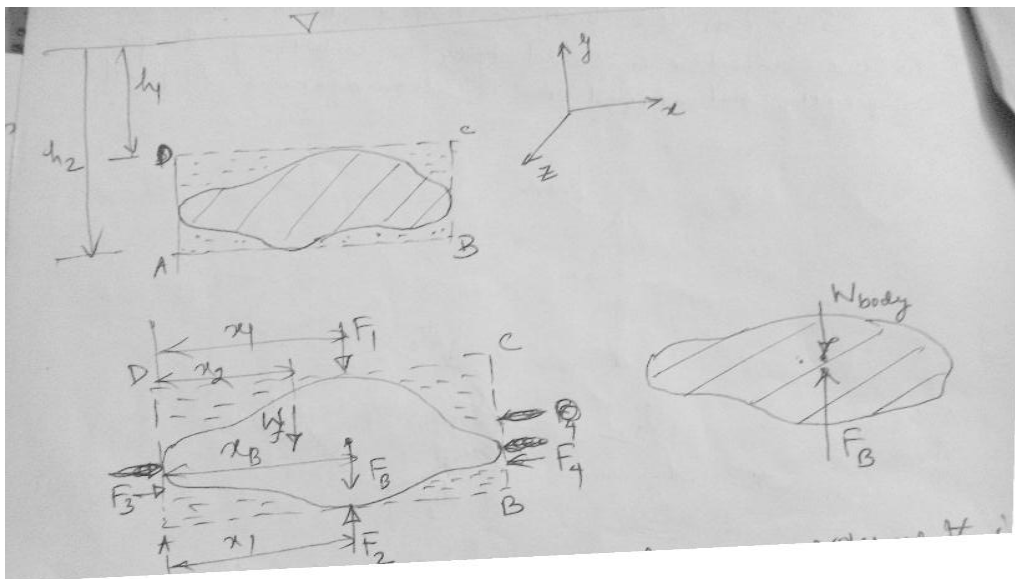

$$F_B x_B = F_2 x_1 - F_1 x_1 - W_f x_2$$

Substituting the forces; we have

$$\nabla x_B = \nabla_T x_1 - (\nabla_T - \nabla) x_2$$

Where  $\nabla_T = A(h_2 - h_1)$ . The right hand side is the first moment of the displaced volume  $\nabla$  and is equal to the centroid of the volume  $\nabla$ . Similarly it can be shown that the 'Z' co-ordinate of buoyant force coincides with 'Z' co-ordinate of the centroid.

$$x_B = \frac{\nabla_T x_1 - (\nabla_T - \nabla) x_2}{\nabla}$$

# Fundamentals of Fluid Mechanics

## Stability:-

Another interesting and important problem associated with submerged as well as floating body is concerned with the stability of the bodies.

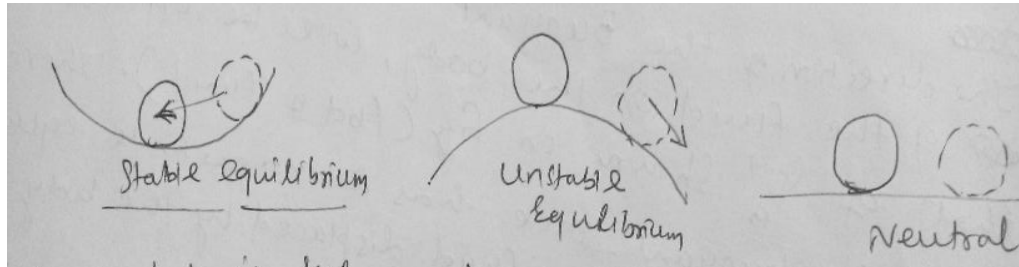

When a body is submerged, the equilibrium requires that the weight of the body acting through its C.G should be collinear with the buoyancy force. However in general, if the body is not homogeneous in distribution of mass over the entire volume, the location of centre of gravity 'G' don't coincide with the centre of volume i.e centre of buoyancy, 'B'. Depending upon the relative location of G & B, a floating or submerged body attains different states of equilibrium, namely (i) Stable equilibrium (ii) Unstable equilibrium (iii) Neutral equilibrium.

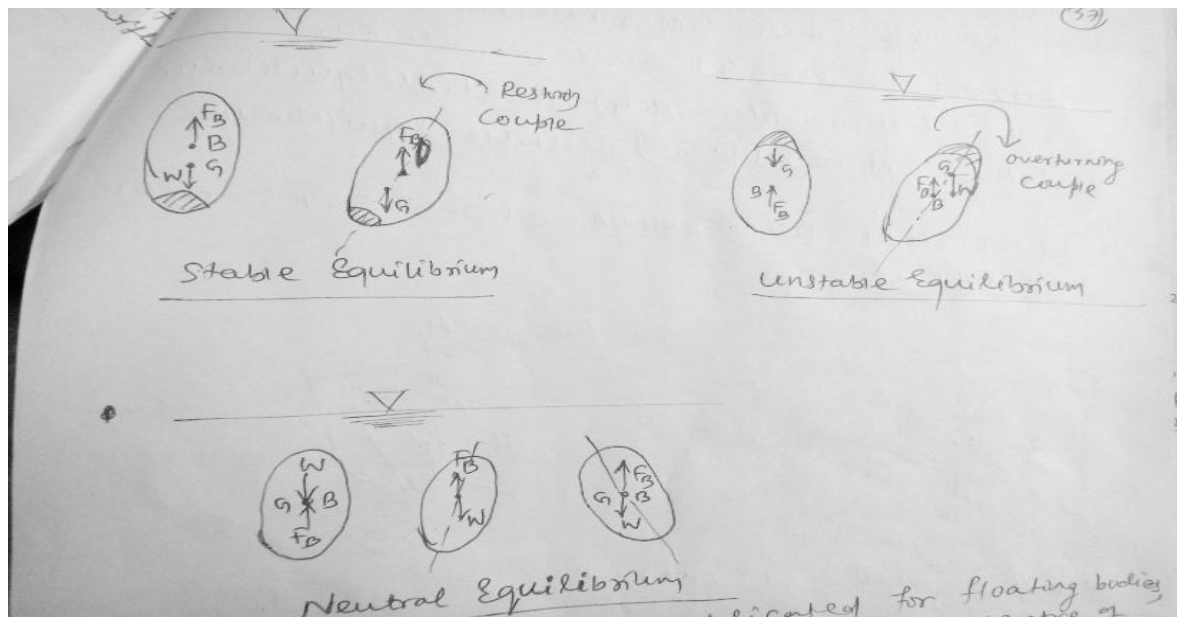

# Fundamentals of Fluid Mechanics

## Stability of submerged Bodies

#Stability problem is more complicated for floating bodies, since as the body rotates the location of centre of Buoyancy (centroid of displaced volume) may change.

$GM = BM - BG$ , where  $\rightarrow$  Metacentric Height

If  $GM > 0$  (M is above G) Stable equilibrium

$GM = 0$  (M coincides with G) Neutral Equilibrium

$GM < 0$  (M is below G) Unstable equilibrium

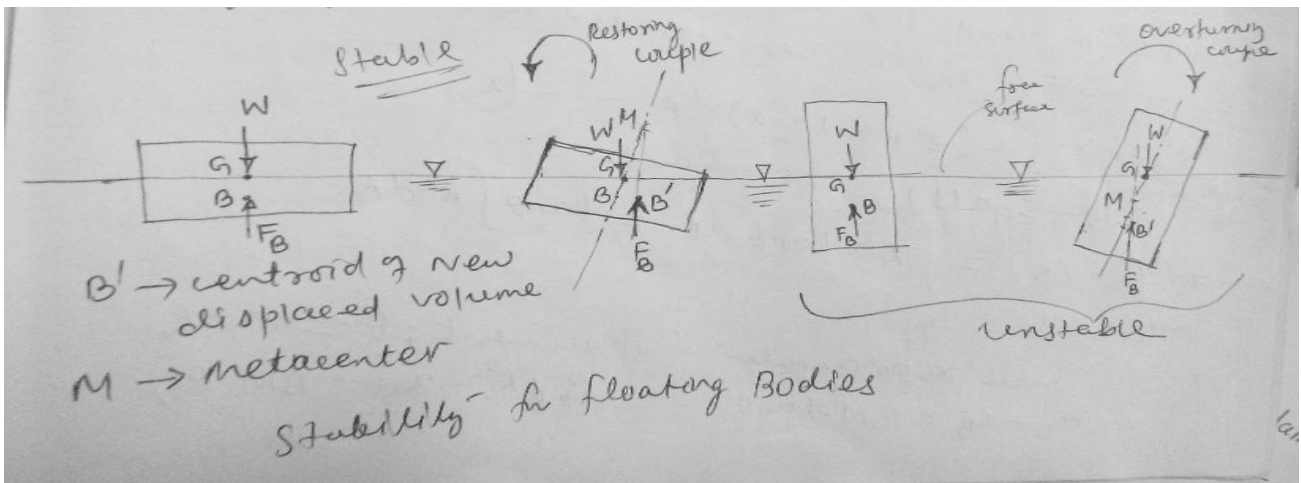

## # Theoretical Determination of Metacentric Height:

Before Displacement

$$x_B \nabla = \int x d \nabla = \int x(z dA) \rightarrow (1)$$

After Displacement, depth of elemental volume immersed is  $(z + x \tan \theta)$  and the new centre of Buoyancy  $x_B'$  can be expressed as :

$$x_B' \nabla = \int x(z + x \tan \theta) dA \rightarrow (2)$$

Subtracting eq.1 from eq.2, we have

$$\nabla(x_B' - x_B) = \int x^2 \tan \theta dA = \tan \theta \int x^2 dA$$

$$\text{But } \int x^2 dA = I_{yy}$$

Also, for small angular displacement ;  $\theta = \tan \theta$

$$x_{B'} - x_B = BM \tan\theta \quad (\text{as } x_{B'} - x_B = BM \theta)$$

Since,  $\forall BM \tan\theta = \tan\theta I_{yy}$

- $BM = \frac{I_{yy}}{\forall}$  #Notice that  $I_{yy}$  is the M.I at the plain of floatation
- $GM + BG = \frac{I_{yy}}{\forall}$  #Notice that  $\forall$  is the immersed volume
- $GM = \frac{I_{yy}}{\forall} - BG$

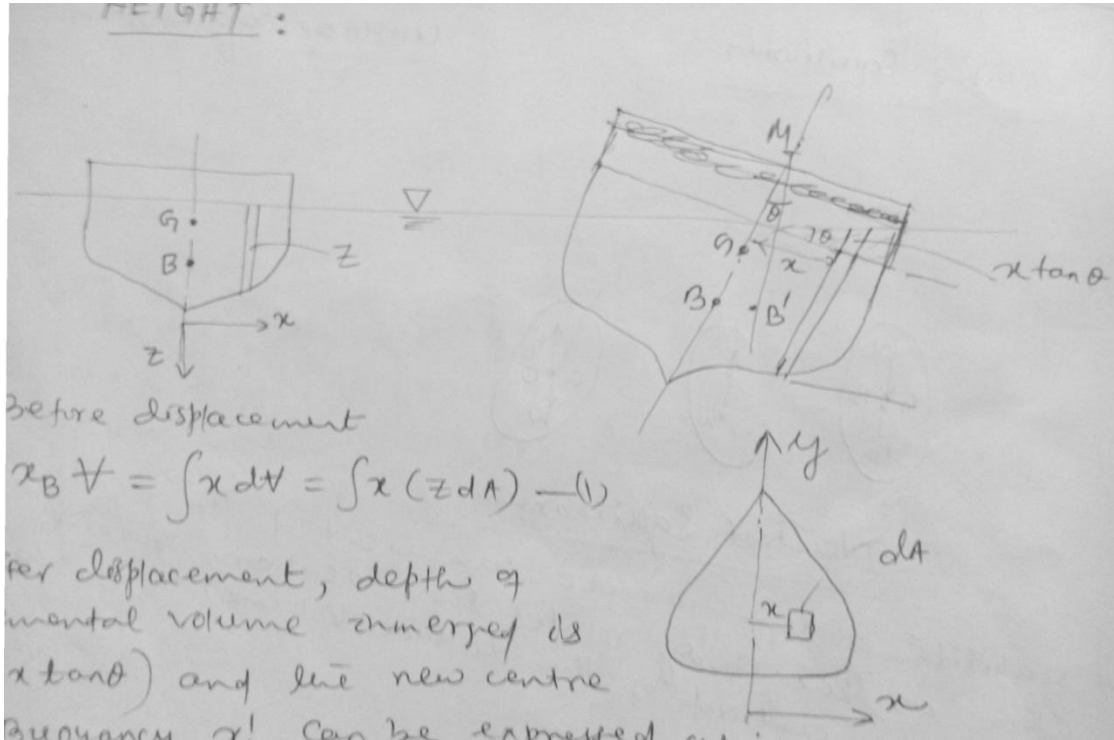

**Fig: Theoretical Determination of Metacentric Height:**

### #Floating Bodies Containing Liquid:-

If a floating body carrying liquid with free surface undergoes an angular displacement, the liquid will move to keep the free surface horizontal. Thus not only the centre of buoyancy moves, but also the centre of gravity 'G' moves, in the direction of the movement of 'B'.

Thus, the stability of the body is reduced. For this reason, liquid which has to be carried in a ship is put into a number of separate compartments so as to minimize its movement within the ship.

### #Period of oscillation:

From previous discussion we know that restoring couple to bring back the body to its original equilibrium position is :  $WGM \sin\theta$

Since the torque is equal to mass moment of inertia ; we can write

$$WGM \sin\theta = - I_M \left( \frac{d^2\theta}{dt^2} \right), \text{ where } I_M \rightarrow \text{mass M.I of the body about its of rotation.}$$



# Fundamentals of Fluid Mechanics

If 'θ' is small,  $\sin\theta = \theta$ , and equation can be written as,  $\frac{d^2\theta}{dt^2} + \frac{W.G.M}{I_M}\theta = 0 \rightarrow (3)$

Eqn (3) represents an SHM.

The time period,  $T = \frac{2\pi}{\omega} = \frac{2\pi}{\left(\frac{W.G.M}{I_M}\right)^{\frac{1}{2}}} = 2\pi \left(\frac{I_M}{W.G.M}\right)^{\frac{1}{2}}$

Here time period is the time taken for a complete oscillation from one side to other and back again. The oscillation of the body results in a flow of the liquid around it and this flow has been neglected here.

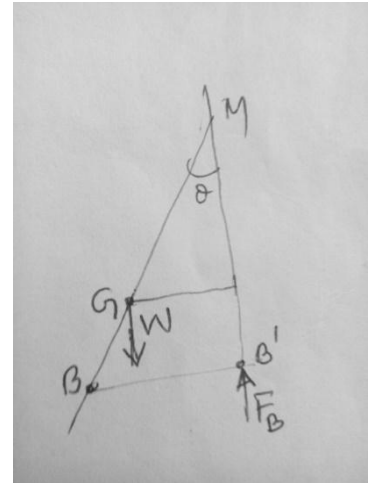

Ex-1

A rectangular barge of width b and a submerged depth of H has its centre of gravity at its waterline. Find the metacentric height in terms of  $\frac{b}{H}$  & hence show that for stable equilibrium of the barge  $\frac{b}{H} \geq \sqrt{6}$ .

Soln:

Given that  $OG = H$

Also from geometry

$$OB = \frac{H}{2}, \quad BG = OG - OB = H - \frac{H}{2} = \frac{H}{2}$$

$$BM = \frac{I}{V} = \frac{LB^3}{12 \times LbH} \quad (\text{Notice that } V \text{ is the immersed volume})$$

$$BM = \frac{b^2}{12H}$$

$$GM = BM - BG = \frac{b^2}{12H} - \frac{H}{2} = \frac{H}{2} \left\{ \frac{1}{6} \left(\frac{b}{H}\right)^2 - 1 \right\}$$

For stable equilibrium of the barge;  $MG \geq 0$

$$\frac{H}{2} \left\{ \frac{1}{6} \left(\frac{b}{H}\right)^2 - 1 \right\} \geq 0$$

$$\Rightarrow \left(\frac{b}{H}\right) \geq \sqrt{6} \quad \text{proved.}$$

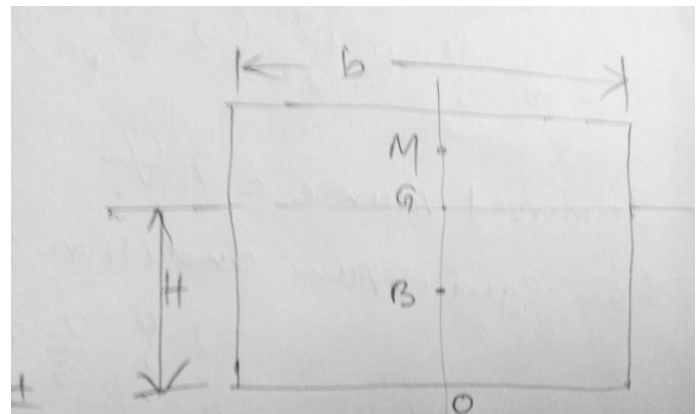



## CHAPTER – 3

### INTRODUCTION TO DIFFERENTIAL ANALYSIS OF FLUID MOTION

#### Differential analysis of fluid motion:

Integral equations are useful when we are interested on the gross behaviour of a flow field and its effect on various devices. However the integral approach doesn't enable us to obtain detailed point by point knowledge of flow field.

To obtain this detailed knowledge, we must apply the equations of fluid motion in differential form.

#### Conservation of mass/continuity equation:

The assumption that a fluid could be treated as a continuous distribution of matter – led directly to a field representation of fluid properties. The property fields are defined by continuous functions of the space coordinates and time. The density and velocity fields are related by conservation of mass.

Continuity equation in rectangular co-ordinate system:-

Let us consider a differential control volume of size  $\Delta x$ ,  $\Delta y$  and  $\Delta z$ .

Rate of change of mass inside the control volume = mass flux in – mass flux out ——— (1)

#### Mass fluxes:

At left face:  $\rho u \Delta y \Delta z$

At right face:  $\rho u \Delta y \Delta z + \frac{\partial(\rho u \Delta y \Delta z)}{\partial x} \Delta x$

At bottom face:  $\rho v \Delta x \Delta z$

At top face:  $\rho v \Delta x \Delta z + \frac{\partial(\rho v \Delta x \Delta z)}{\partial y} \Delta y$

At back face:  $\rho w \Delta x \Delta y + \frac{\partial(\rho w \Delta x \Delta y)}{\partial z} \Delta z$

Applying equation (1):

$$\frac{\partial(\rho \Delta x \Delta y \Delta z)}{\partial t} = - \frac{\partial(\rho u)}{\partial x} \Delta x \Delta y \Delta z - \frac{\partial(\rho v)}{\partial y} \Delta x \Delta y \Delta z - \frac{\partial(\rho w)}{\partial z} \Delta x \Delta y \Delta z$$

$$\Rightarrow \frac{\partial \rho}{\partial t} + \frac{\partial(\rho u)}{\partial x} + \frac{\partial(\rho v)}{\partial y} + \frac{\partial(\rho w)}{\partial z} = 0$$

$$\Rightarrow \frac{\partial \rho}{\partial t} + \nabla \cdot (\rho \vec{u}) = 0 \quad \text{————— (2)}$$

To find the expression for an incompressible flow:

$$\begin{aligned} \frac{\partial \rho}{\partial t} + \rho \nabla \cdot \vec{u} + \vec{u} \cdot \nabla \rho &= 0 \\ \Rightarrow \left( \frac{\partial \rho}{\partial t} + \vec{u} \cdot \nabla \rho \right) + \rho \nabla \cdot \vec{u} &= 0 \\ \Rightarrow \frac{D\rho}{Dt} + \rho \nabla \cdot \vec{u} &= 0 \end{aligned} \quad (3)$$

Let us define;  $\vec{u}^* = \frac{\vec{u}}{u_{ref}}$ ;  $x_i^* = \frac{x_i}{L}$

$$\begin{aligned} \nabla \cdot \vec{u} &= \frac{u_{ref}}{L} (\nabla^* \cdot u^*) \quad [ \text{Since } \nabla \cdot \vec{u} = \frac{\partial u_i}{\partial x_i} = \frac{u_{ref}}{L} \frac{\partial u_i^*}{\partial x_i^*} ] \\ \Rightarrow \frac{u_{ref}}{L} (\nabla^* \cdot u^*) &= - \frac{1}{\rho} \frac{D\rho}{Dt} \\ \Rightarrow (\nabla^* \cdot u^*) &= - \frac{1}{\left(\frac{u_{ref}}{L}\right)} \cdot \frac{1}{\rho} \frac{D\rho}{Dt} \end{aligned} \quad (4)$$

Eqn (4) may be approximated as  $(\nabla^* \cdot u^*) = 0$

$$\text{If } \left[ \frac{1}{\left(\frac{u_{ref}}{L}\right)} \cdot \frac{1}{\rho} \frac{D\rho}{Dt} \right] \ll 1 \quad (5)$$

The velocity field is approximately solenoidal if condition (5) is satisfied.

For incompressible flow,  $\rho = \text{constant}$  is a wrong statement. (unfortunately such statements appear in standard books).

For example: Sea water or stratified air where density varies from layer to layer but the flow is essentially incompressible as the density of the particles along its path line don't change.

$$\frac{D\rho}{Dt} = 0, \text{ doesn't necessarily mean that } \rho = \text{constant}$$

Hence, for incompressible flow;

$$\nabla \cdot \vec{u} = 0, \text{ doesn't matter whether the flow is steady or unsteady.}$$

# If  $\rho = \text{constant}$  then the flow is incompressible, but the converse is not true, i.e. Incompressible flow, the density may or may not be constant.

## MOMENTUM EQUATION:

A dynamic equation describing fluid motion may be obtained by applying Newton's 2<sup>nd</sup> law to a particle.

Newton's 2<sup>nd</sup> law for a finite system is given by:

$$\vec{F} = \left( \frac{d\vec{P}}{dt} \right)_{\text{system}} \quad (1)$$

# Fundamentals of Fluid Mechanics

---

where the linear momentum 'P' is given by:

$$\vec{P}_{system} = \int_{mass} \vec{V} dm \quad (2)$$

Then, for an infinitesimal system of mass 'dm', Newton's 2<sup>nd</sup> law can be written as:

$$d\vec{F} = dm \left( \frac{d\vec{V}}{dt} \right) \quad (3)$$

The total derivative  $\frac{d\vec{V}}{dt}$  in equation (3) can be expressed as:

$$u \frac{\partial \vec{V}}{\partial x} + v \frac{\partial \vec{V}}{\partial y} + w \frac{\partial \vec{V}}{\partial z} + \frac{\partial \vec{V}}{\partial t}$$

Hence;

$$d\vec{F} = dm \left[ u \frac{\partial \vec{V}}{\partial x} + v \frac{\partial \vec{V}}{\partial y} + w \frac{\partial \vec{V}}{\partial z} + \frac{\partial \vec{V}}{\partial t} \right] \quad (4)$$

Now the force  $d\vec{F}$  acting on the fluid element can be expressed as sum of the surface forces (both Normal forces and tangential forces) and body forces (includes gravity field, electric field or magnetic fields).

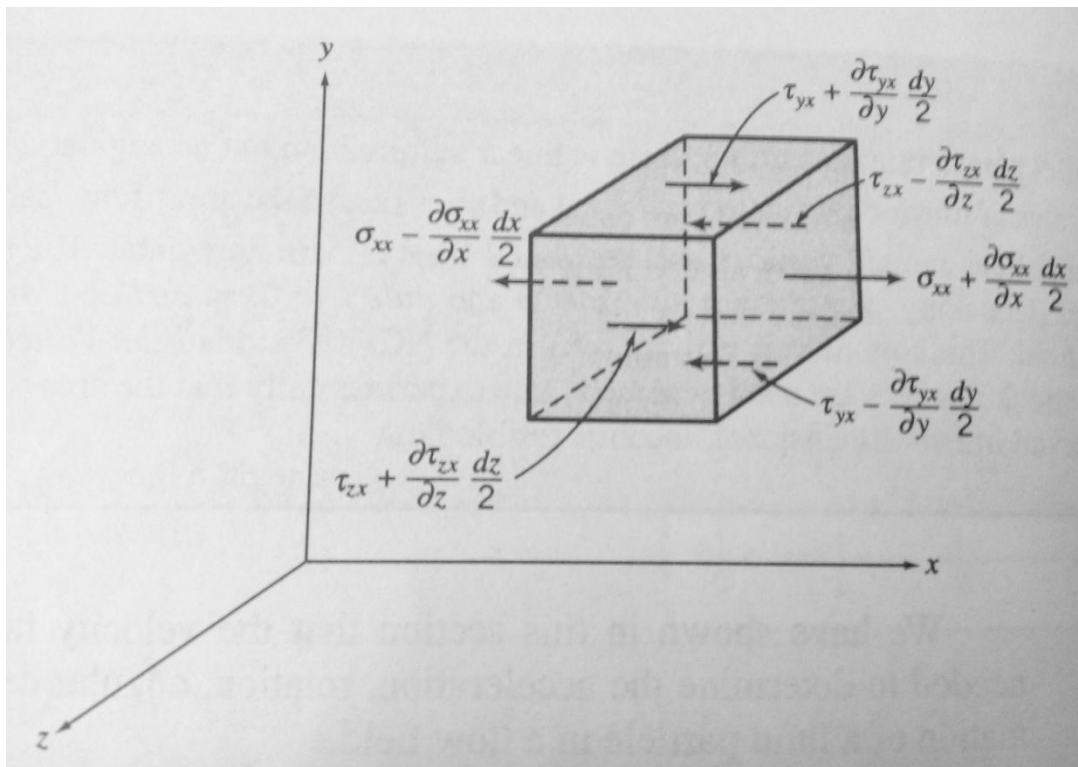

To obtain the surface forces in x- direction we must sum the forces in x direction. Thus,

$$dF_{sx} = (\sigma_{xx} + \frac{\partial \sigma_{xx}}{\partial x} dx) dy dz - \sigma_{xx} dy dz + (\sigma_{yx} + \frac{\partial \sigma_{yx}}{\partial y}) dx dz - \sigma_{yx} dx dz + (\sigma_{zx} + \frac{\partial \sigma_{zx}}{\partial z}) dx dy - \sigma_{zx} dx dy$$

On simplifying , we obtain ;

$$dF_{sx} = \left( \frac{\partial \sigma_{xx}}{\partial x} + \frac{\partial \sigma_{yx}}{\partial y} + \frac{\partial \sigma_{zx}}{\partial z} \right) dx dy dz$$

$$dF_x = dF_{sx} + dF_{bx} = \rho g_x + \left( \frac{\partial \sigma_{xx}}{\partial x} + \frac{\partial \sigma_{yx}}{\partial y} + \frac{\partial \sigma_{zx}}{\partial z} \right) dx dy dz \quad \text{————— (5) ———}$$

Similar expression for the force components in y & z direction are:

$$dF_y = \rho g_y + \left( \frac{\partial \sigma_{xy}}{\partial x} + \frac{\partial \sigma_{yy}}{\partial y} + \frac{\partial \sigma_{zy}}{\partial z} \right) dx dy dz \quad \text{————— (6) ———}$$

$$dF_z = \rho g_z + \left( \frac{\partial \sigma_{xz}}{\partial x} + \frac{\partial \sigma_{yz}}{\partial y} + \frac{\partial \sigma_{zz}}{\partial z} \right) dx dy dz \quad \text{————— (7) ———}$$

Now writing the differential form of equation of motion:

$$(\rho g_x + \frac{\partial \sigma_{xx}}{\partial x} + \frac{\partial \sigma_{yx}}{\partial y} + \frac{\partial \sigma_{zx}}{\partial z}) = \rho \left( \frac{\partial u}{\partial t} + u \frac{\partial u}{\partial x} + v \frac{\partial u}{\partial y} + w \frac{\partial u}{\partial z} \right) \quad \text{————— (8) ———}$$

$$(\rho g_y + \frac{\partial \sigma_{xy}}{\partial x} + \frac{\partial \sigma_{yy}}{\partial y} + \frac{\partial \sigma_{zy}}{\partial z}) = \rho \left( \frac{\partial v}{\partial t} + u \frac{\partial v}{\partial x} + v \frac{\partial v}{\partial y} + w \frac{\partial v}{\partial z} \right) \quad \text{————— (9) ———}$$

$$(\rho g_z + \frac{\partial \sigma_{xz}}{\partial x} + \frac{\partial \sigma_{yz}}{\partial y} + \frac{\partial \sigma_{zz}}{\partial z}) = \rho \left( \frac{\partial w}{\partial t} + u \frac{\partial w}{\partial x} + v \frac{\partial w}{\partial y} + w \frac{\partial w}{\partial z} \right) \quad \text{————— (10) ———}$$

Newtonian fluid :- Navier-stokes equation:

The stresses may be expressed in terms of velocity gradients & fluid properties in rectangular co-ordinates as follows :

$$\sigma_{xy} = \sigma_{yx} = \mu \left( \frac{\partial v}{\partial x} + \frac{\partial u}{\partial y} \right)$$

$$\sigma_{yz} = \sigma_{zy} = \mu \left( \frac{\partial w}{\partial y} + \frac{\partial v}{\partial z} \right)$$

$$\sigma_{zx} = \sigma_{xz} = \mu \left( \frac{\partial u}{\partial z} + \frac{\partial w}{\partial x} \right)$$

$$\sigma_{xx} = -P - \frac{2}{3} \mu \nabla \cdot \vec{V} + 2 \mu \frac{\partial u}{\partial x}$$

$$\sigma_{yy} = -P - \frac{2}{3} \mu \nabla \cdot \vec{V} + 2 \mu \frac{\partial v}{\partial y}$$

$$\sigma_{zz} = -P - \frac{2}{3} \mu \nabla \cdot \vec{V} + 2 \mu \frac{\partial w}{\partial z}$$

$$\sigma_{av} = \frac{1}{3} (\sigma_{xx} + \sigma_{yy} + \sigma_{zz})$$

$$\sigma_{av} = -P - 2\mu \nabla \cdot \vec{V} + 2\mu \nabla \cdot \vec{V}$$

$$P_m = P - \mathcal{X} (\nabla \cdot \vec{V})$$

Where ‘P’ is the local thermodynamic pressure, and ‘X’ is co-efficient of bulk viscosity.

### Stream function for two dimensional incompressible flow:

It is convenient to have a means of describing mathematically any particular pattern of flow. A mathematical device that serves this purpose is the stream function,  $\psi$ . The stream function is formulated as a relation between the streamlines and the statement of conservation of mass. The stream function  $\psi(x, y, t)$  is a single mathematical function that replaces two velocity components,  $u(x, y, t)$  and  $v(x, y, t)$ .

For a two dimensional incompressible flow in the xy plane, conservation of mass can be written as:  $\frac{\partial u}{\partial x} + \frac{\partial v}{\partial y} = 0$ .

If a continuous function  $\psi(x, y, t)$  called stream function is defined such that  $u = \frac{\partial \psi}{\partial y}$  and  $v = -\frac{\partial \psi}{\partial x}$ , then the continuity equation is satisfied exactly.

Then  $\frac{\partial u}{\partial x} + \frac{\partial v}{\partial y} = \frac{\partial^2 \psi}{\partial x \partial y} - \frac{\partial^2 \psi}{\partial y \partial x} = 0$  and the continuity equation is satisfied exactly.

If  $\vec{ds}$  is an element of length along the stream line, the equation of streamline is given by:

$$\vec{V} \times \vec{ds} = 0 = (iu + jv) \times (idx + jdy) = k(udy - vdx)$$

Thus equation of streamline in a two dimensional flow is:  $udy - vdx = 0$

Then we can write:  $\frac{\partial \psi}{\partial x} dx + \frac{\partial \psi}{\partial y} dy = 0$  ----- (1)

Since  $\psi = \psi(x, y, t)$  then at any instant  $t_0$ ,  $\psi = \psi(x, y, t_0)$ . Thus at a given instant a change in  $\psi$  may be evaluated as  $\psi = \psi(x, y)$ .

Thus at any instant,  $d\psi = \frac{\partial \psi}{\partial x} dx + \frac{\partial \psi}{\partial y} dy$  ----- (2)

# Fundamentals of Fluid Mechanics

---

Comparing Eqn.1 and 2, we see that along an instantaneous streamline  $d\psi = 0$  or  $\psi$  is constant along a streamline. Since differential of  $\psi$  is exact, the integral of  $d\psi$  between any two points in a flow field depends on the end points only, i.e.  $\psi_2 - \psi_1$ .

## Example problem: Stream Function flow in a corner:

The velocity field for a steady, incompressible flow is given as:  $\vec{V} = Axi - Ayj$  with  $A=0.3s^{-1}$

Determine the stream function that will yield this velocity field. Plot and interpret the streamlines in the first quadrant of xy plane:

Solution:  $u = Ax = \frac{\partial \psi}{\partial y}$

Integration with respect to y yields:

$$\psi = \int \frac{\partial \psi}{\partial y} dy + f(x) = Axy + f(x) ;$$

where  $f(x)$  is an arbitrary function of x.

$f(x)$  can be evaluated using the expression for v.

Thus we can write,

$$v = -\frac{\partial \psi}{\partial x} = -Ay - \frac{df}{dx} .$$

But from the velocity field description,  $v = -Ay$ . Hence  $\frac{df}{dx} = 0$  or  $f(x) = \text{constant}$ .

Thus,  $\psi = Axy + c$ . The c is arbitrary constant and can be chosen as zero without any loss in generality. With  $c=0$  and  $A=0.3s^{-1}$ , we have,  $\psi = Axy$ . The streamlines in the 1<sup>st</sup> quadrant is shown in Fig. Regions of high speed flow occur where the streamlines are close together. Lower-speed flow occurs near the origin, where the streamline spacing is wider. The flow looks like flow in a corner formed by a pair of walls.

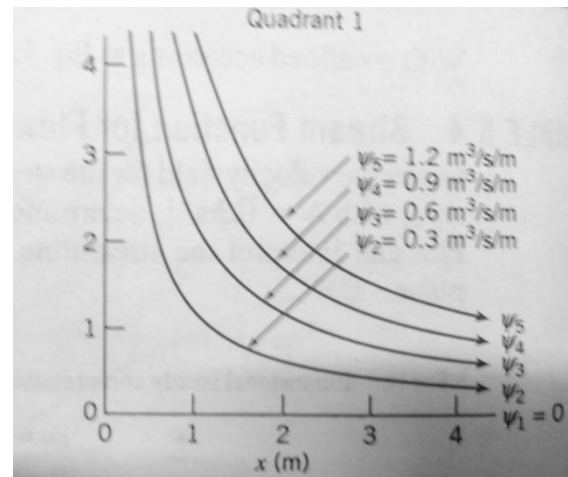



Before formulating the effects of force on fluid motion (dynamics), let us consider first the motion (kinematics) of a fluid element on a flow field. For convenience, we follow a infinitesimal element of a fixed identity (mass)

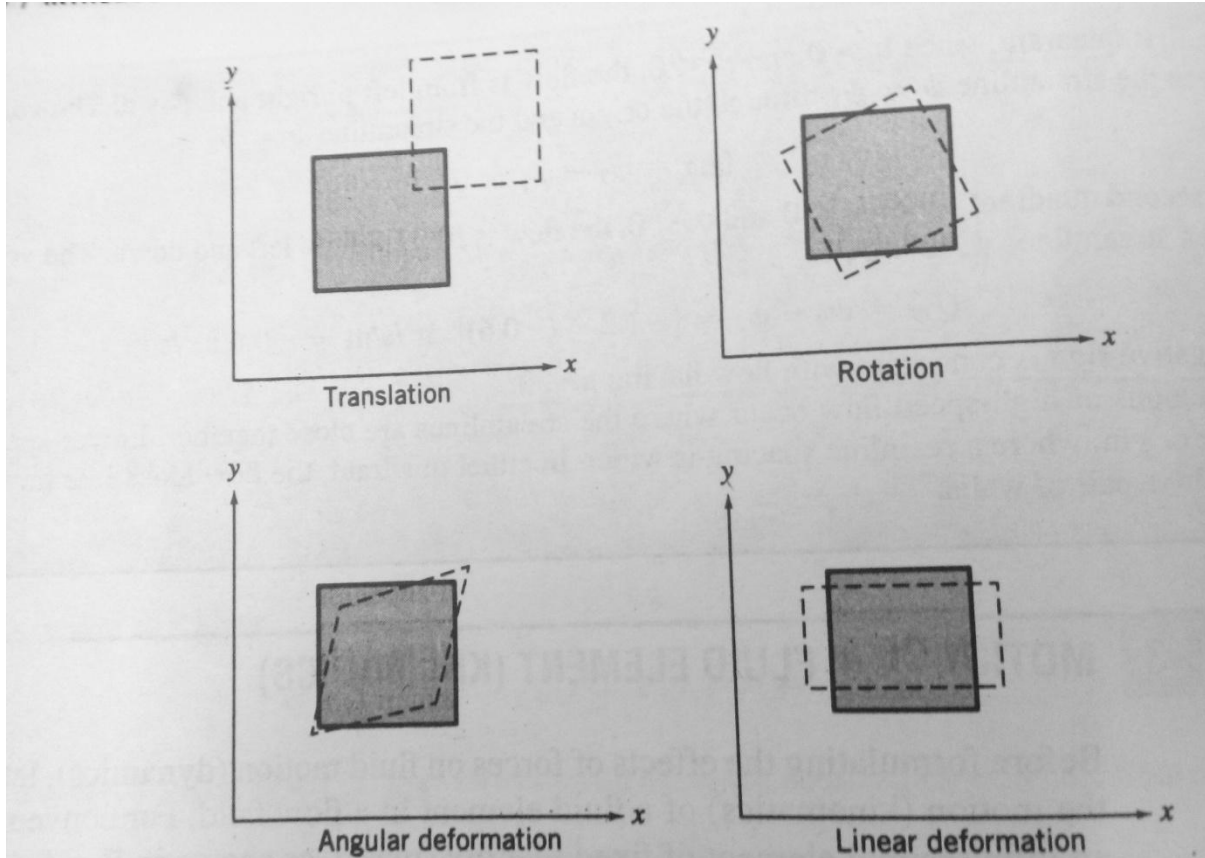

As the infinitesimal element of mass ' $dm$ ' moves in a flow field, several things may happen to it. Certainly the element translates, it undergoes a linear displacement from  $x,y,z$  to  $x_1,y_1,z_1$ . The element may also rotate (no change in the included angle in adjacent sides). In addition the element may deform i.e. it may undergo linear and angular deformation. Linear deformation involves a deformation in which planes of element that were originally perpendicular remain perpendicular. Angular deformation involves a distortion of the element in which planes that were originally perpendicular do not remain perpendicular. In general a fluid element may undergo a combination of translation, rotation, linear deformation and angular deformation during the course of its motion.

For pure translation or rotation, the fluid element retains its shape, there is no deformation. Thus shear stress doesn't arise as a result of pure translation or rotation (since for a

Newtonian fluid the shear stress is directly proportional to the rate of angular deformation). We shall consider fluid translation, rotation and deformation in turn.

**Fluid translation:** Acceleration of a fluid particle in a velocity field. A general description of a particle acceleration can be obtained by considering a particle moving in a velocity field. The basic hypothesis of continuum fluid mechanics has led us to a field description of fluid flow in which the properties of flow field are defined by continuous functions of space and time. In particular, the velocity field is given by  $\vec{V} = \vec{V}(x, y, z, t)$ . The field description is very powerful, since information for the entire flow is given by one equation.

The problem, then is to retain the field description for the fluid properties and obtain an expression for acceleration of a fluid particle as it moves in a flow field. Stated simply, the problem is:

Given the velocity field  $\vec{V} = \vec{V}(x, y, z, t)$ , find the acceleration of a fluid particle,  $\vec{a}_p$ .

Consider the particle moving in a velocity field. At time 't', the particle is at the position x, y, z and has velocity corresponding to velocity at that point in space at time 't', i.e.

$$\vec{V}_p|_t = \vec{V}(x, y, z, t).$$

At 't+dt', the particle has moved to a new position with co-ordinates x+dx, y+dy, z+dz and has a velocity given by:  $\vec{V}_p|_{t+dt} = \vec{V}(x+dx, y+dy, z+dz, t+dt)$ .

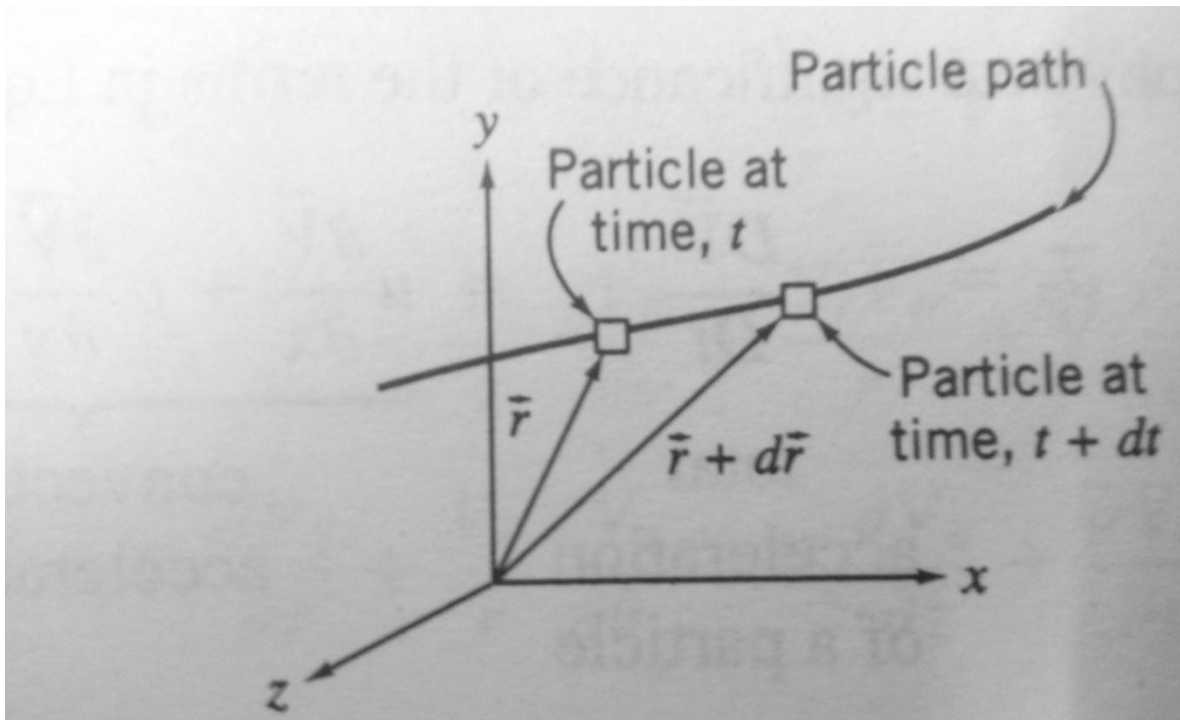

Fig4.1

This is shown in pictorial fig 4.1

$\overline{dV}_p$ , the change in velocity of the particle, in moving from location  $\vec{r}$  to  $\vec{r} + d\vec{r}$ , is given by:

$$\overline{dV}_p = \frac{\partial \vec{V}}{\partial x} dx_p + \frac{\partial \vec{V}}{\partial y} dy_p + \frac{\partial \vec{V}}{\partial z} dz_p + \frac{\partial \vec{V}}{\partial t} dt$$

The total acceleration of the particle is given by :

$$\vec{a}_p = \frac{d\vec{V}_p}{dt} = \frac{\partial \vec{V}}{\partial x} \frac{dx_p}{dt} + \frac{\partial \vec{V}}{\partial y} \frac{dy_p}{dt} + \frac{\partial \vec{V}}{\partial z} \frac{dz_p}{dt} + \frac{\partial \vec{V}}{\partial t}$$

Since  $\frac{dx_p}{dt} = u$ ,  $\frac{dy_p}{dt} = v$  and  $\frac{dz_p}{dt} = w$ ,

$$\vec{a}_p = \frac{d\vec{V}_p}{dt} = u \frac{\partial \vec{V}}{\partial x} + v \frac{\partial \vec{V}}{\partial y} + w \frac{\partial \vec{V}}{\partial z} + \frac{\partial \vec{V}}{\partial t}$$

$$\frac{D\vec{V}}{Dt} = \vec{a}_p = \frac{d\vec{V}_p}{dt} = u \frac{\partial \vec{V}}{\partial x} + v \frac{\partial \vec{V}}{\partial y} + w \frac{\partial \vec{V}}{\partial z} + \frac{\partial \vec{V}}{\partial t} \quad \text{-----} \quad (4.1)$$

The derivative  $\frac{D\vec{V}}{Dt}$  is commonly called substantial derivative to remind us that it is computed for a particle of substance. It is often called material derivative or particle derivative.

From equation 4.1 we recognize that a fluid particle moving in a flow field may undergo acceleration for either of the two reasons. It may be accelerated because it is convected into a region of higher (lower) velocity. For example, the steady flow through a nozzle, in which by definition, the velocity field is not a function of time, a fluid particle will accelerate as it moves through the nozzle. The particle is convected into a region of higher velocity. If a flow field is unsteady the fluid particle will undergo an additional “local” acceleration, because the velocity field is a function of time.

The physical significance of the terms in the equation 4.1 is :

$$u \frac{\partial \vec{V}}{\partial x} + v \frac{\partial \vec{V}}{\partial y} + w \frac{\partial \vec{V}}{\partial z} = \text{convective acceleration}$$

$$\frac{\partial \vec{V}}{\partial t} = \text{local acceleration.}$$

Therefore equation 4.1 can be written as:

$$\vec{a}_p = \frac{D\vec{V}}{Dt} = (\vec{V} \cdot \nabla) \vec{V} + \frac{\partial \vec{V}}{\partial t}$$

For a steady and three dimensional flow the equation 4.1 becomes:

# Fundamentals of Fluid Mechanics

---

$$\frac{D\vec{V}}{Dt} = u \frac{\partial \vec{V}}{\partial x} + v \frac{\partial \vec{V}}{\partial y} + w \frac{\partial \vec{V}}{\partial z}; \text{ which is not necessarily zero.}$$

Equation 4.1 may be written in scalar component equation as:

$$a_{xp} = \frac{Du}{Dt} = u \frac{\partial u}{\partial x} + v \frac{\partial u}{\partial y} + w \frac{\partial u}{\partial z} + \frac{\partial u}{\partial t} \quad \text{----- (4.2 a)}$$

$$a_{yp} = \frac{Dv}{Dt} = u \frac{\partial v}{\partial x} + v \frac{\partial v}{\partial y} + w \frac{\partial v}{\partial z} + \frac{\partial v}{\partial t} \quad \text{----- (4.2 b)}$$

$$a_{zp} = \frac{Dw}{Dt} = u \frac{\partial w}{\partial x} + v \frac{\partial w}{\partial y} + w \frac{\partial w}{\partial z} + \frac{\partial w}{\partial t} \quad \text{----- (4.2 c)}$$

We have obtained an expression for the acceleration of a particle anywhere in the flow field; this is the Eulerian method of description. One substitutes the coordinates of the point into the field expression for acceleration.

In the Lagrangian method of description, the motion (position, velocity and acceleration) of a fluid particle is described as a function of time.

**Fluid rotation:** A fluid particle moving in a general three dimensional flow field may rotate about all three coordinate axes. The particle rotation is a vector quantity and in general  $\vec{\omega} = \hat{i} \omega_x + \hat{j} \omega_y + \hat{k} \omega_z$ ; where  $\omega_x$  is the rotation about  $x$  axis.

To evaluate the components of particle rotation vector, we define the angular velocity about an axis as the average angular velocity of two initially perpendicular differential line segments in a plane perpendicular to the axis of rotation.

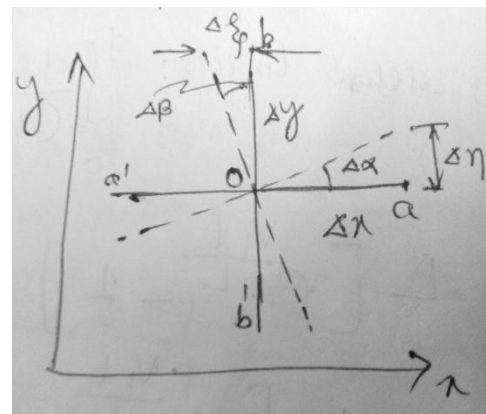
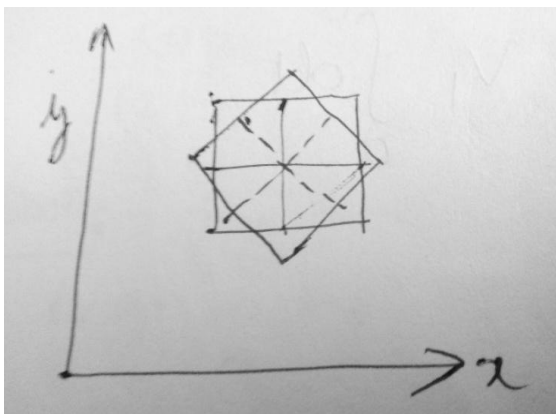

To obtain a mathematical expression for  $\omega_z$ , the component of fluid rotation about the  $z$  axis, consider motion of fluid in  $x$ - $y$  plane. The components of velocity at every point in the field

are given by  $u(x,y)$  and  $v(x,y)$ . Consider first the rotation of line segment  $oa$  of length  $\Delta x$ . Rotation of this line is due to the variation of 'y' component of velocity. If the 'y' component of the velocity at point 'o' is taken as  $V_o$ , then the 'y' component velocity at point 'a' can be written using Taylor expansion series as:

$$V = V_o + \frac{\partial v}{\partial x} \Delta x$$

$$\omega_{oa} = \lim_{\Delta t \rightarrow 0} \frac{\Delta \alpha}{\Delta t} = \lim_{\Delta t \rightarrow 0} \frac{\frac{\Delta \eta}{\Delta x}}{\Delta t}$$

$$\text{since } \Delta \eta = (V_a - V_o) \Delta t = \frac{\partial v}{\partial x} \Delta x \Delta t$$

$$\omega_{oa} = \lim_{\Delta t \rightarrow 0} \frac{\left(\frac{\partial v}{\partial x}\right)(\Delta x \Delta t)}{\Delta x \Delta t} = \frac{\partial v}{\partial x}$$

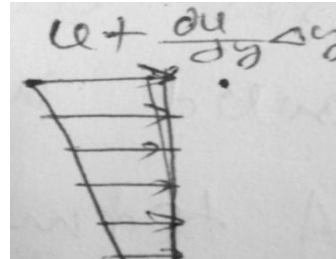

The angular velocity of 'ob' is obtained similarly. If the x- component of velocity at point 'b' is  $u_o + \frac{\partial u}{\partial y} \Delta y$

$$\omega_{ob} = \lim_{\Delta t \rightarrow 0} \frac{\Delta \beta}{\Delta t} = \lim_{\Delta t \rightarrow 0} \frac{\frac{\Delta \xi}{\Delta y}}{\Delta t}$$

$u_b = \frac{\partial u}{\partial y} \Delta y$ ; which will rotate the fluid element in clock-wise direction, thus -ve sign is multiplied to make it counter clock-wise direction.

$$\text{But } \Delta \xi = - \frac{\partial u}{\partial y} \Delta y \Delta t \quad (\text{-ve sign is used to give +ve value of } \omega_{ob})$$

$$\text{Thus } \omega_{ob} = \lim_{\Delta t \rightarrow 0} \frac{-\left(\frac{\partial u}{\partial y}\right)(\Delta y \Delta t)}{\Delta y \Delta t} = - \frac{\partial u}{\partial y}$$

The rotation of fluid element about z- axis is the average angular velocity of the two mutually perpendicular line segments,  $oa$  and  $ob$ , in the x-y plane.

$$\text{Thus } \omega_z = \frac{1}{2} \left[ \frac{\partial v}{\partial x} - \frac{\partial u}{\partial y} \right]$$

By considering the rotation about other axes :

$$\omega_x = \frac{1}{2} \left[ \frac{\partial w}{\partial y} - \frac{\partial v}{\partial z} \right] \quad \text{and} \quad \omega_y = \frac{1}{2} \left[ \frac{\partial u}{\partial z} - \frac{\partial w}{\partial x} \right]$$

Then  $\vec{\omega} = \frac{1}{2} \left[ \left( \frac{\partial w}{\partial y} - \frac{\partial v}{\partial z} \right) \hat{i} + \left( \frac{\partial u}{\partial z} - \frac{\partial w}{\partial x} \right) \hat{j} + \left( \frac{\partial v}{\partial x} - \frac{\partial u}{\partial y} \right) \hat{k} \right]$ ; which can be written in vector notation as :

$$\boxed{\vec{\omega} = \frac{1}{2} \nabla \times \vec{V}}$$

Under what conditions might we expect to have a flow without rotation ( irrotational flow ) ?

A fluid particle moving, without any rotation, in a flow field cannot develop rotation under the action of body force or normal surface forces. Development of rotation in fluid particle, initially without rotation, requires the action of shear stresses on the surface of the particle. Since shear stress is proportional to the rate of angular deformation, then a particle that is initially without rotation will not develop a rotation without simultaneous angular deformation. The shear stress is related to the rate of angular deformation through viscosity. The presence of viscous force means the flow is rotation.

The condition of irrotationality may be a valid assumption for those regions of a flow in which viscous forces are negligible. (For example , such a region exists outside the boundary layer in the flow over a solid surface.)

A term vorticity is defined as twice of the rotation as:

$$\vec{\zeta} = 2 \vec{\omega} = \nabla \times \vec{V}$$

The circulation,  $\Gamma$  is defined as the line integral of the tangential velocity component about a closed curve fixed in the flow ;  $\Gamma = \oint_c \vec{V} \cdot d\vec{S}$

where  $d\vec{S}$  elemental vector tangent to the curve , a positive sense corresponds to a counter clock-wise path of integration around the curve. A relation between circulation and vorticity can be obtained by considering the fluid element as shown:

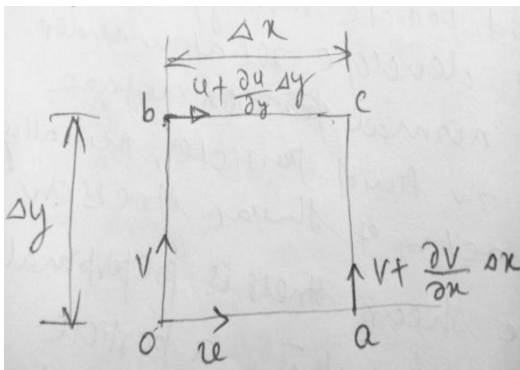

$$\Delta\Gamma = u\Delta x + \left(v + \frac{dv}{dx}\Delta x\right)\Delta y - \left(u + \frac{du}{dy}\Delta y\right)\Delta x - v\Delta y$$

$$= \left(\frac{dv}{dx} - \frac{du}{dy}\right)\Delta x\Delta y = 2\omega_z \Delta x\Delta y$$

$$\Gamma = \oint \Delta\Gamma = \oint_c \vec{V} \cdot d\vec{S}$$

$$= \int_A 2\omega_z dA$$

$$\Rightarrow \Gamma = \int_A (\nabla \times \vec{V})_z dA$$

# Fundamentals of Fluid Mechanics

---

Angular deformation: Angular deformation of a fluid element involves changes in the perpendicular line segments on the fluid.

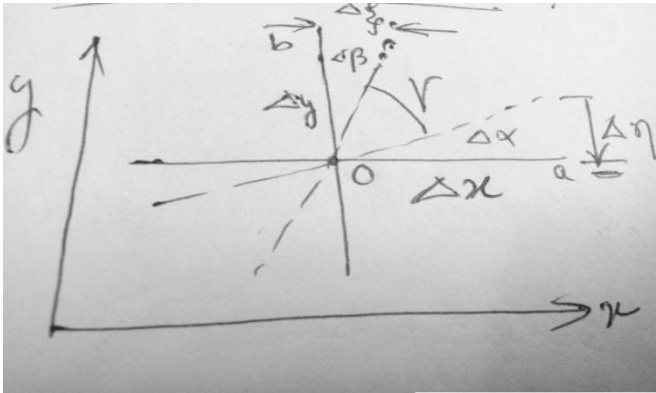

We see that the rate of angular deformation of the fluid element in the  $xy$  plane is the rate of decrease of angle “ $\gamma$ ” between the line  $oa$  and  $ob$ . Since during interval  $\Delta t$ ,

$$\Delta \gamma = \gamma - 90 = -(\Delta \alpha + \Delta \beta)$$

$$\Rightarrow -\frac{d\gamma}{dt} = \frac{d\alpha}{dt} + \frac{d\beta}{dt}$$

Now;

$$\frac{d\alpha}{dt} = \frac{dv}{dx} \quad \text{and} \quad \frac{d\beta}{dt} = \frac{du}{dy}$$

## INCOMPRESSIBLE INVISCID FLOW

All real fluids possess viscosity. However, in many flow cases it is reasonable to neglect the effect of viscosity. It is useful to investigate the dynamics of an ideal fluid that is incompressible and has zero viscosity. The analysis of ideal fluid motion is simpler because no shear stresses are present in inviscid flow. Normal stresses are the only stresses that must be considered in the analysis. For a non-viscous fluid in motion, the normal stress at a point is the same in all directions (scalar quantity) and equals to the negative of the thermodynamic pressure,  $\sigma_{nn} = -P$ .

### Momentum equation for frictionless flow: Euler's equations:

The equations of motion for frictionless flow, called Euler's equations, can be obtained from the general equations of motion, by putting  $\mu = 0$  and  $\sigma_{nn} = -p$ .

$$\rho g_x - \frac{\partial P}{\partial x} = \rho \left( \frac{\partial u}{\partial t} + u \frac{\partial u}{\partial x} + v \frac{\partial u}{\partial y} + w \frac{\partial u}{\partial z} \right)$$

$$\rho g_y - \frac{\partial P}{\partial y} = \rho \left( \frac{\partial v}{\partial t} + u \frac{\partial v}{\partial x} + v \frac{\partial v}{\partial y} + w \frac{\partial v}{\partial z} \right)$$

$$\rho g_z - \frac{\partial P}{\partial z} = \rho \left( \frac{\partial w}{\partial t} + u \frac{\partial w}{\partial x} + v \frac{\partial w}{\partial y} + w \frac{\partial w}{\partial z} \right)$$

In vector form it can be written as:

$$\rho \vec{g} - \nabla P = \rho \left( \frac{\partial \vec{V}}{\partial t} + u \frac{\partial \vec{V}}{\partial x} + v \frac{\partial \vec{V}}{\partial y} + w \frac{\partial \vec{V}}{\partial z} \right)$$

$$\Rightarrow \rho \vec{g} - \nabla P = \rho \left( \frac{\partial \vec{V}}{\partial t} + (\vec{V} \cdot \nabla) \vec{V} \right)$$

$$\Rightarrow \boxed{\rho \vec{g} - \nabla P = \rho \frac{D\vec{V}}{Dt}}$$

In cylindrical co-ordinates:

$$r: \rho g_r - \frac{\partial P}{\partial r} = \rho \left( \frac{\partial V_r}{\partial t} + V_r \frac{\partial V_r}{\partial r} + \frac{V_\theta}{r} \frac{\partial V_r}{\partial \theta} + V_z \frac{\partial V_r}{\partial z} - \frac{V_\theta^2}{r} \right)$$

$$\theta: \rho g_\theta - \frac{1}{r} \frac{\partial P}{\partial \theta} = \rho \left( \frac{\partial V_\theta}{\partial t} + V_r \frac{\partial V_\theta}{\partial r} + \frac{V_\theta}{r} \frac{\partial V_\theta}{\partial \theta} + V_z \frac{\partial V_\theta}{\partial z} + \frac{V_\theta V_r}{r} \right)$$

$$z: \rho g_z - \frac{\partial P}{\partial z} = \rho \left( \frac{\partial V_z}{\partial t} + V_r \frac{\partial V_z}{\partial r} + \frac{V_\theta}{r} \frac{\partial V_z}{\partial \theta} + V_z \frac{\partial V_z}{\partial z} \right)$$



# Fundamentals of Fluid Mechanics

## Euler's equations in streamline co-ordinates:

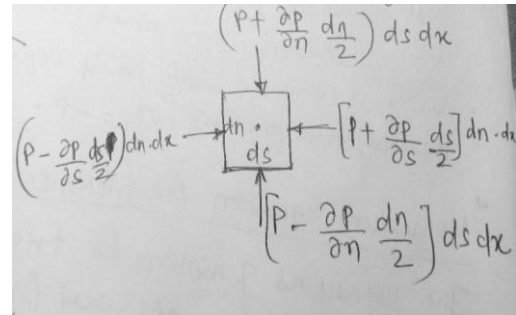
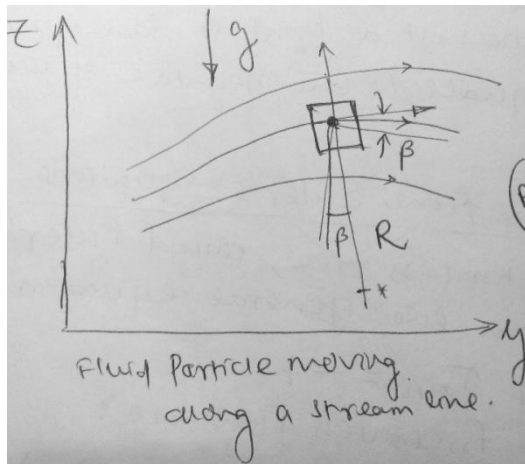

Applying Newton's 2<sup>nd</sup> law in streamwise (the 's') direction to the fluid element of volume  $ds \times dn \times dx$ , and neglecting viscous forces we obtain:

$$\left(P - \frac{\partial P}{\partial s} \frac{ds}{2}\right) dn dx - \left(P + \frac{\partial P}{\partial s} \frac{ds}{2}\right) dn dx - \rho g \sin\beta ds dn dx = \rho a_s ds dn dx$$

Simplifying the equation we have:

$$-\frac{\partial P}{\partial s} - \rho g \sin\beta = \rho a_s$$

Since  $\sin\beta = \frac{\partial z}{\partial s}$ , we can write:

$$-\frac{\partial P}{\partial s} - \rho g \frac{\partial z}{\partial s} = \rho \frac{D\vec{V}}{Dt} = \rho \left(\frac{\partial V}{\partial t} + V \frac{\partial V}{\partial s}\right)$$

$$\Rightarrow \boxed{-\frac{1}{\rho} \frac{\partial P}{\partial s} - g \frac{\partial z}{\partial s} = \frac{\partial V}{\partial t} + V \frac{\partial V}{\partial s}}$$

To obtain Euler's equation in a direction normal to the streamlines, we apply Newton's 2<sup>nd</sup> law in the 'n' direction to the fluid element. Again, neglecting viscous forces; we obtain:

$$\left(P - \frac{\partial P}{\partial n} \frac{dn}{2}\right) ds dx - \left(P + \frac{\partial P}{\partial n} \frac{dn}{2}\right) ds dx - \rho g \cos\beta dn dx ds = \rho a_n dn dx ds$$

where ' $\beta$ ' is the angle between 'n' direction and vertical and ' $a_n$ ' is the acceleration of the fluid particle in 'n' direction.

$$-\frac{\partial P}{\partial n} - \rho g \cos\beta = \rho a_n$$

Since  $\cos\beta = \frac{\partial z}{\partial n}$ , we can write:

$$-\frac{1}{\rho} \frac{\partial P}{\partial n} - g \frac{\partial z}{\partial n} = a_n$$

The normal acceleration of the fluid element is towards the centre of curvature of the streamline; in the negative 'n' direction. Thus  $a_n = -\frac{V^2}{R}$

$$\Rightarrow \boxed{\frac{1}{\rho} \frac{\partial P}{\partial n} + g \frac{\partial z}{\partial n} = \frac{V^2}{R}}$$

For steady flow on a horizontal plane, Euler's equation normal to the streamline can be written as:

$$\Rightarrow \boxed{\frac{1}{\rho} \frac{\partial P}{\partial n} = \frac{V^2}{R}}$$

Above equation indicates that pressure increases in the direction outward from the centre of curvature of streamlines.

### Bernoulli's equation: Integration of Euler's equation along a stream line for steady flow( Derivation using stream line co-ordinates):

Euler's equation for steady flow will be:

$$-\frac{1}{\rho} \frac{\partial P}{\partial s} - g \frac{\partial z}{\partial s} = V \frac{\partial V}{\partial s}$$

If a fluid particle moves a distance 'ds' along a streamline, then

$$\frac{\partial P}{\partial s} ds = dp \quad \text{(the change in pressure along 's')}$$

$$\frac{\partial z}{\partial s} ds = dz \quad \text{(the change in elevation along 's')}$$

$$\frac{\partial V}{\partial s} ds = dV \quad \text{(the change in velocity along 's')}$$

Thus;  $-\frac{dP}{\rho} - g dz = V dV$

$$\Rightarrow \frac{dP}{\rho} + V dV + g dz = 0$$

$$\Rightarrow \int \frac{dP}{\rho} + \frac{V^2}{2} + gz = \text{constant}(\text{along } 's') \quad \text{-----} \quad (5.1)$$

For an incompressible flow, i.e. ' $P$ ' is not a function of ' $\rho$ '; we can write:

$$\frac{P}{\rho} + \frac{V^2}{2} + gz = \text{constant}(\text{along } 's')$$

Restrictions:

- i. Steady flow
- ii. Incompressible flow
- iii. Inviscid
- iv. Flow along a stream line

\* In general the constant has different values along different streamlines.

\* For derivation using rectangular co-ordinates, refer page-7.

Unsteady Bernoulli's equation( Integration of Euler's equation along a stream line):

$$-\frac{1}{\rho} \nabla P - \vec{g} = \frac{D\vec{V}}{Dt} \quad \text{or}$$

$$-\frac{1}{\rho} \frac{\partial P}{\partial s} - g \frac{\partial z}{\partial s} = \frac{\partial V}{\partial t} + V \frac{\partial V}{\partial s}$$

Multiplying  $ds$  and integrating along a stream line between two points '1' and '2',

$$\int_1^2 \frac{dp}{\rho} + \frac{V_2^2 - V_1^2}{2} + g(z_2 - z_1) + \int_1^2 \frac{\partial V}{\partial t} ds = 0$$

For an incompressible flow, the above equation reduces to :

$$\frac{P_1}{\rho} + \frac{V_1^2}{2} + g z_1 = \frac{P_2}{\rho} + \frac{V_2^2}{2} + g z_2 + \int_1^2 \frac{\partial V}{\partial t} ds$$

Restrictions:

- i. Incompressible flow
- ii. Frictionless flow
- iii. Flow along a stream line

## Fundamentals of Fluid Mechanics

---

Ex: A long pipe is connected to a large reservoir that initially is filled with water to a depth of 3 m. The pipe is 150 mm in diameter and 6 m long. Determine the flow velocity leaving the pipe as a function of time after a cap is removed from its free end.

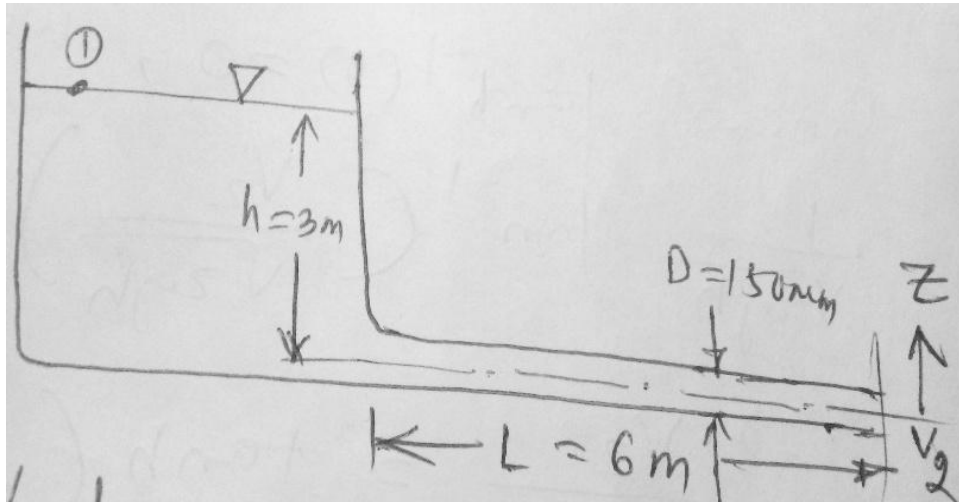

Ans: Applying Bernoulli's equation between 1 and 2 we have:

$$\frac{P_1}{\rho} + \frac{V_1^2}{2} + g z_1 = \frac{P_2}{\rho} + \frac{V_2^2}{2} + g z_2 + \int_1^2 \frac{\partial V}{\partial t} ds$$

Assumptions:

- i. Incompressible flow
- ii. Frictionless flow
- iii. Flow along a stream line for '1' and '2'
- iv.  $P_1 = P_2 = P_{\text{atm}}$
- v.  $V_1 = 0$
- vi.  $Z_2 = 0$
- vii.  $Z_1 = h$
- viii. Neglect velocity in reservoir, except for small region near the inlet to the tube.

$$\text{Then; } g z_1 = g h = \frac{V_2^2}{2} + \int_1^2 \frac{\partial V}{\partial t} ds \quad \text{----- (1)}$$

In view of assumption 'viii', the integral becomes

$$\int_1^2 \frac{\partial V}{\partial t} ds \approx \int_0^L \frac{\partial V}{\partial t} ds$$

In the tube,  $V = V_2$ , everywhere, so that

$$\int_0^L \frac{\partial V}{\partial t} ds = \int_0^L \frac{dV_2}{dt} ds = L \frac{dV_2}{dt}$$

Substituting in the equation (1),

$$g h = \frac{V_2^2}{2} + L \frac{dV_2}{dt}$$

Separating the variables we obtain:

$$\frac{dV_2}{2gh - V_2^2} = \frac{dt}{2L}$$

Integrating between limits  $V = 0$  at  $t = 0$  and  $V = V_2$  at  $t = t$ ,

$$\int_0^{V_2} \frac{dV_2}{2gh - V_2^2}$$

$$= \left[ \frac{1}{\sqrt{2gh}} \tanh^{-1} \left( \frac{V}{\sqrt{2gh}} \right) \right]_0^{V_2} = \frac{t}{2L}$$

Since  $\tanh^{-1}(0) = 0$ , we obtain

$$\frac{1}{\sqrt{2gh}} \tanh^{-1} \left( \frac{V}{\sqrt{2gh}} \right) = \frac{t}{2L}$$

$$\Rightarrow \frac{V_2}{\sqrt{2gh}} = \tanh \left( \frac{t}{2L} \sqrt{2gh} \right)$$

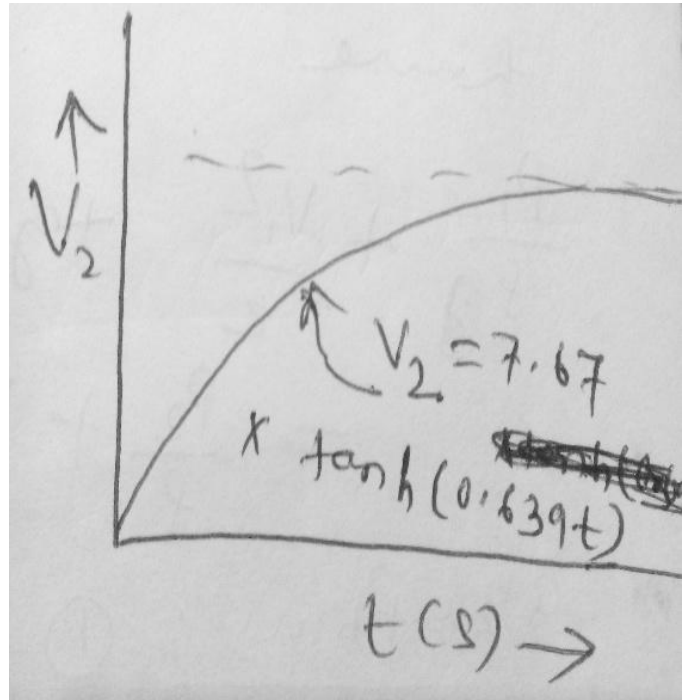

### Bernoulli's equation using rectangular coordinates:

$$-\frac{1}{\rho} \nabla P - g \hat{k} = (\vec{V} \cdot \nabla) \vec{V}$$

Using the vector identity:

$$(\vec{V} \cdot \nabla) \vec{V} = \frac{1}{2} \nabla (\vec{V} \cdot \vec{V}) - \vec{V} \times (\nabla \times \vec{V})$$

For irrotational flow:  $\nabla \times \vec{V} = 0$

$$\text{So } (\vec{V} \cdot \nabla) \vec{V} = \frac{1}{2} \nabla (\vec{V} \cdot \vec{V})$$

$$-\frac{1}{\rho} \nabla P - g \hat{k} = \frac{1}{2} \nabla (\vec{V} \cdot \vec{V}) = \frac{1}{2} \nabla (V^2)$$

# Fundamentals of Fluid Mechanics

---

Consider a displacement in the flow field from position ' $\vec{r}$ ' to ' $\vec{r} + d\vec{r}$ ', the displacement ' $d\vec{r}$ ' being an arbitrary infinitesimal displacement in any direction. Taking the dot product of  $d\vec{r} = dx \hat{i} + dy \hat{j} + dz \hat{k}$  with each of the terms, we have

$$-\frac{1}{\rho} \nabla P \cdot d\vec{r} - g \hat{k} \cdot d\vec{r} = \frac{1}{2} \nabla (V^2) \cdot d\vec{r}$$

And hence  $-\frac{dP}{\rho} - g dz = \frac{1}{2} d(V^2)$

$$\Rightarrow \frac{dP}{\rho} + \frac{1}{2} d(V^2) + g dz = 0$$

$$\Rightarrow \boxed{\frac{P}{\rho} + \frac{V^2}{2} + g z = \text{constant}} \quad \text{----- (5.2)}$$

Since ' $d\vec{r}$ ' was an arbitrary displacement, equation '5.2' is valid between any two points in a steady, incompressible and inviscid flow that is irrotational.

If ' $d\vec{r}$ ' = ' $d\vec{s}$ ' i.e. the integration is to be performed along a stream line, then taking the dot product of  $d\vec{s}$ , we get:

$$(\vec{V} \cdot \nabla) \vec{V} \cdot d\vec{s} = \frac{1}{2} \nabla (\vec{V} \cdot \vec{V}) \cdot d\vec{s} - \vec{V} \times (\nabla \times \vec{V}) \cdot d\vec{s}$$

Here even though  $(\nabla \times \vec{V})$  is not zero, the product  $\vec{V} \times (\nabla \times \vec{V}) \cdot d\vec{s}$

will be zero as  $\vec{V} \times (\nabla \times \vec{V})$  is perpendicular to  $V$  and hence perpendicular to  $d\vec{s}$ .

# A fluid that is initially irrotational may become rotational if:-

1. There are significant viscous forces induced by jets, wakes or solid boundaries. In these cases Bernoulli's equation will not be valid in such viscous regions.
2. There are entropy gradients caused by shock waves.
3. There are density gradients caused by stratification (uneven heating) rather than by pressure gradients.
4. There are significant non inertial effects such as earth's rotation (The Coriolis component).

## HGL and EGL:

Hydraulic Grade Line (HGL) corresponds to the pressure head and elevation head i.e. Energy Grade Line(EGL) minus the velocity head.

$$\text{EGL} = \frac{P}{\rho g} + \frac{V^2}{2g} + z = H \quad (\text{Total Bernoulli's constant})$$

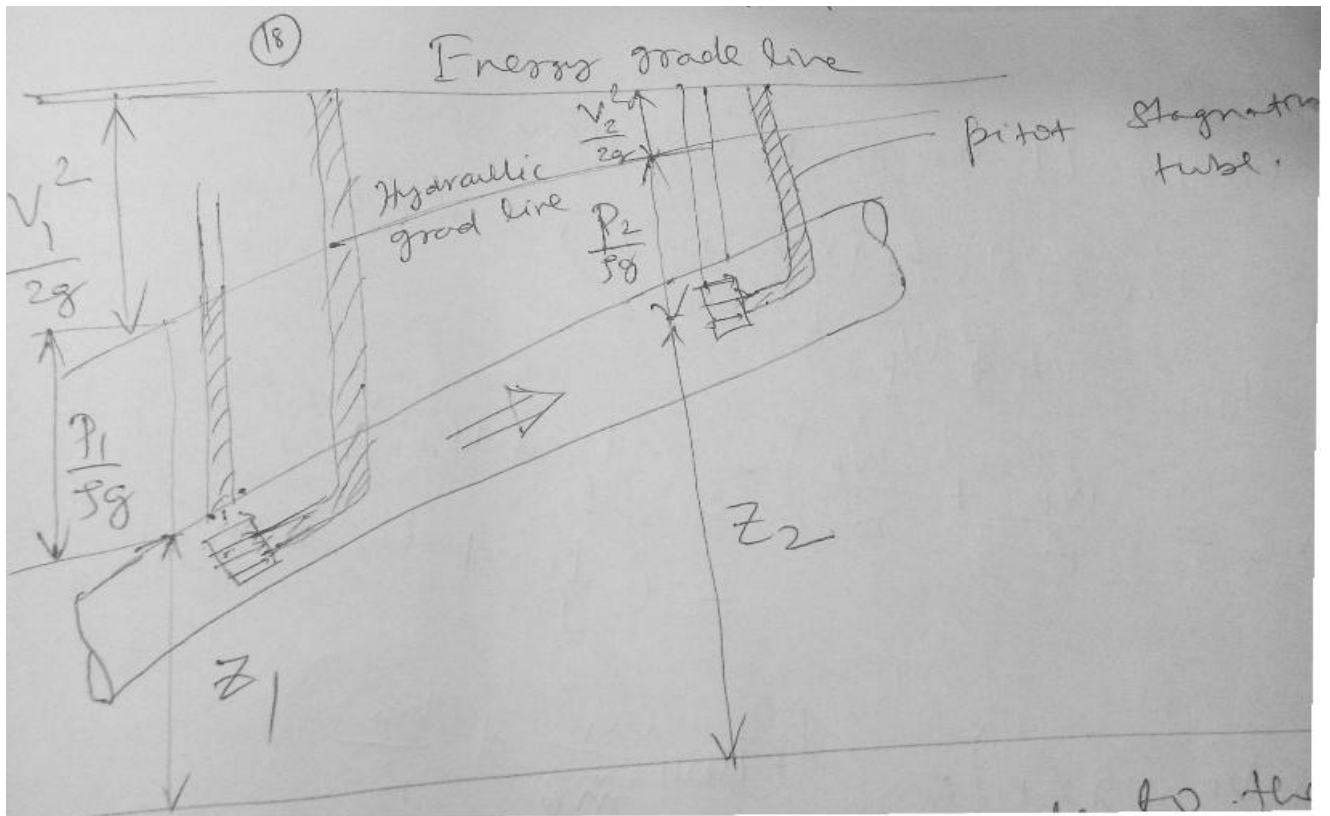

**Principles of a hydraulic Siphon:** Consider a container T containing some liquid. If one end of the pipe S completely filled with same liquid, is dipped into the container with the other end being open and vertically below the free surface of the liquid in the container T, then liquid will continuously flow from the container T through pipe S and get discharged at the end B. This is known as siphonic action and the justification of flow can be explained by applying the Bernoulli's equation.

Applying the Bernoulli's equation between point A and B, we can write

$$\frac{P_A}{\rho g} + 0 + Z_A = \frac{P_B}{\rho g} + \frac{V_B^2}{2g} + Z_B$$

The pressure at A and B are same and equal to atmospheric pressure. Velocity at A is negligible compared to velocity at B, since the area of the tank T is very large compared to that of the tube S. Hence we get,

$$V_B = \sqrt{2g(Z_A - Z_B)} = \sqrt{2g\Delta Z}$$

The above expression shows that a velocity head at B is created at the expenses of the potential head difference between A and B.

Applying the Bernoulli's equation between point A and B, we can write

$$\frac{P_A}{\rho g} + 0 + Z_A = \frac{P_C}{\rho g} + \frac{V_C^2}{2g} + Z_C$$

Considering the pipe cross section to be uniform, we have, from continuity,  $V_B = V_C$

Thus we can write; 
$$\frac{P_C}{\rho g} = \frac{P_{atm}}{\rho g} - \frac{V_B^2}{2g} - h$$

Therefore pressure at C is below atmospheric and pressure at D is the lowest as the potential head is maximum here. The pressure at D should not fall below the vapor pressure of the liquid, as this may create vapor pockets and may stop the flow.



## CHAPTER-4

Laminar flow through a pipe.

Assumptions:

- a) Steady
- b) Parallel flow in Z- direction  $V_r = 0$  and  $V_z = u \neq 0$
- c) Constant property fluid ( $\rho$  &  $\mu$  are constant)
- d) Axisymmetric;  $\frac{\partial}{\partial \theta} = 0$   $V_\theta = 0$

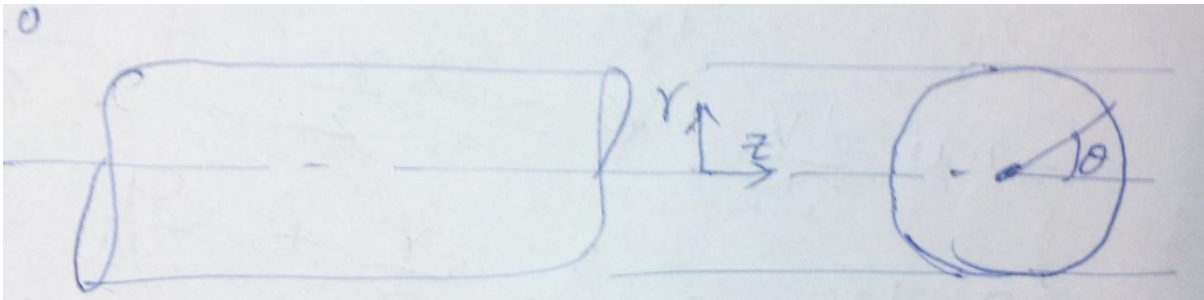

Continuity Equation:

$$\frac{1}{r} \frac{\partial (rV_r)}{\partial r} + \frac{1}{r} \frac{\partial V_\theta}{\partial \theta} + \frac{\partial V_z}{\partial z} = 0$$

Since  $V_r = 0 = V_\theta$ ; we have;

$$\frac{\partial V_z}{\partial z} = 0 \Rightarrow V_z = V_z(r, \theta)$$

But  $\frac{\partial V_z}{\partial \theta} = 0$  (Axisymmetric)

$\Rightarrow V_z = V_z(r) = V(r)$

Consider a differential annular control volume:

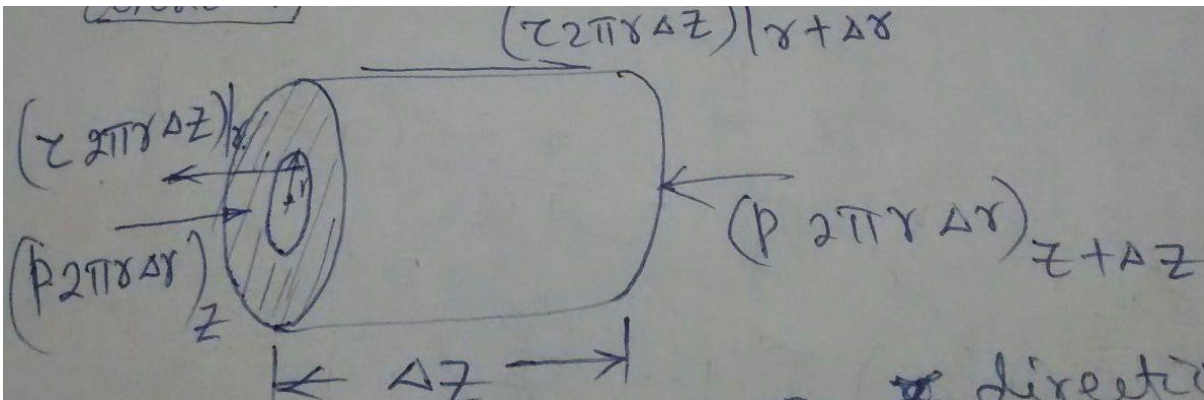

Applying the force balance in Z-direction, we have

$$(P \ 2\pi r \ \Delta r)_z + (2\pi r \ \Delta z \ \tau)_{r+\Delta r} - (P \ 2\pi r \ \Delta r)_{z+\Delta z} - (2\pi r \ \Delta z \ \tau)_r = 0$$

$$\Rightarrow (P_z - P_{z+\Delta z}) \ 2\pi r \ \Delta r + 2\pi \ \Delta z \ [(\tau r)_{r+\Delta r} - (\tau r)_r] = 0$$

$$\Rightarrow -\left(\frac{P_{z+\Delta z} - P_z}{\Delta z}\right) + \frac{1}{r} \frac{\partial(\tau r)}{\partial r} = 0$$

$$\Rightarrow \frac{1}{r} \frac{d}{dr} \left( r\mu \frac{dv}{dr} \right) = \frac{\partial P}{\partial z} = \frac{dP}{dz} = \lambda \text{ ( a constant)}$$

$$\Rightarrow \frac{d}{dr} \left[ r\mu \frac{dv}{dr} \right] = r \lambda$$

$$\Rightarrow r\mu \frac{dv}{dr} = \lambda \frac{r^2}{2} + c_1$$

$$\Rightarrow \mu \frac{dv}{dr} = \lambda \frac{r}{2} + \frac{c_1}{r}$$

$$\Rightarrow \frac{dv}{dr} = \frac{\lambda r}{\mu 2} + \frac{c_1}{\mu r}$$

$$\Rightarrow v = \frac{\lambda r^2}{\mu 4} + \frac{c_1}{\mu} \ln r + c_2$$

At  $r = R$ ;  $V = 0$  (No slip B C)

At  $r = 0$ ;  $V = \text{finite}$

The RHS of the equation will be finite only if  $c_1 = 0$ .

$$\text{Thus; } v = \frac{\lambda r^2}{\mu 4} + c_2$$

$$\text{At } r = R; 0 = \frac{\lambda R^2}{\mu 4} + c_2$$

$$\Rightarrow c_2 = -\frac{\lambda R^2}{\mu 4}$$

$$\Rightarrow v = \frac{\lambda r^2}{\mu 4} - \frac{\lambda R^2}{\mu 4} = \frac{\lambda}{4\mu} (r^2 - R^2)$$

$$\Rightarrow v = -\left(\frac{dP}{dz}\right) \left(\frac{R^2}{4\mu}\right) \left[1 - \left(\frac{r}{R}\right)^2\right]$$

H.W- Evaluate  $Q = \int \bar{v} \cdot d\bar{A} = \int_0^R v \ 2\pi r \ dr$

$$\Rightarrow Q = -\frac{\pi R^4}{8\mu} \left(\frac{dP}{dz}\right)$$

## Head loss- the friction factor

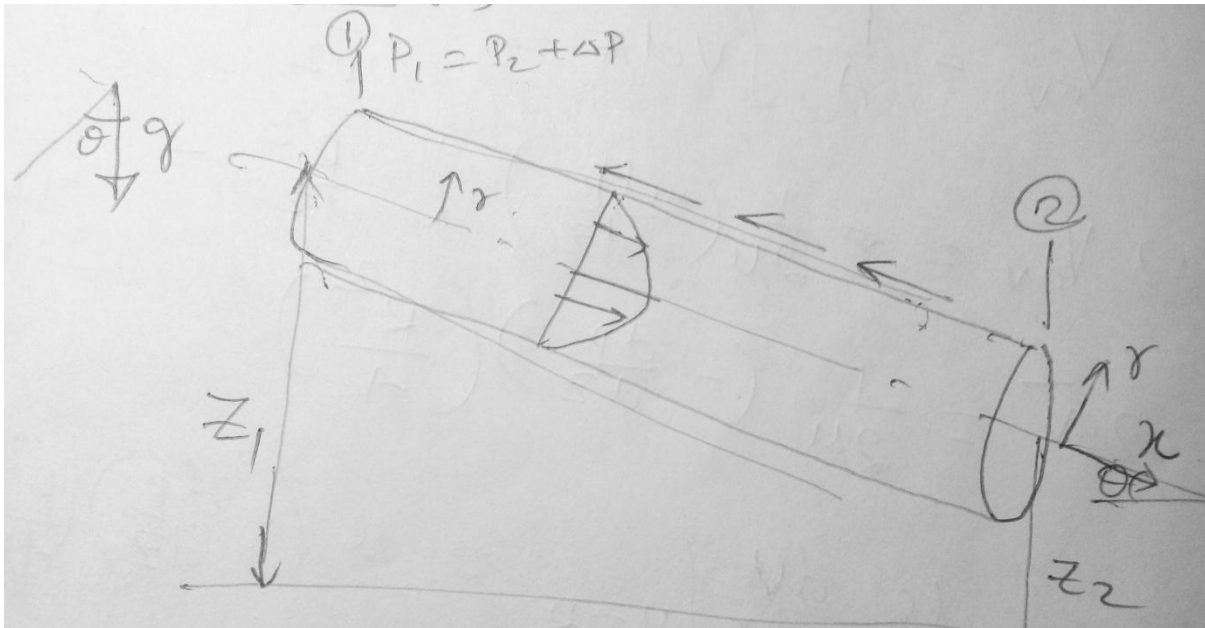

The SFEE between (1) & (2) gives;

$$\left( \frac{P_1}{\rho g} + \alpha_1 \frac{\bar{v}_1^2}{2g} + z_1 \right) = \left( \frac{P_2}{\rho g} + \alpha_2 \frac{\bar{v}_2^2}{2g} + z_2 \right) + h_f$$

$\alpha_1 = \alpha_2$  and  $\bar{v}_1 = \bar{v}_2$  [velocity profile is not changing from 1 to 2 & c.s area is constant]

$$\text{Thus } h_f = (z_1 - z_2) + \left( \frac{P_1}{\rho g} - \frac{P_2}{\rho g} \right) \text{----- (1)}$$

Applying the momentum relation to the control volume

$$(P_1 \pi R^2 - P_2 \pi R^2) - \tau_w 2\pi R L + \rho g (\pi R^2 L) \sin \theta = \dot{m}(\bar{v}_1 - \bar{v}_2) = 0$$

$$\Rightarrow \frac{P_1 - P_2}{\rho g} + (z_1 - z_2) = \frac{2\tau_w}{\rho g} \frac{L}{R} = \frac{4\tau_w}{\rho g} \frac{L}{D} \text{----- (2)}$$

Comparing eqn. (1) & (2), we have;

$$h_f = \frac{4\tau_w}{\rho g} \frac{L}{D}$$

$$v = - \left( \frac{dP}{dz} \right) \frac{R^2}{4\mu} \left[ 1 - \frac{r^2}{R^2} \right]$$

$$v_{av} = \frac{1}{A} \int v dA = \frac{1}{\pi R^2} - \left( \frac{dP}{dz} \right) \left( \frac{R^2}{4\mu} \right) \int_0^R \left( 1 - \frac{r^2}{R^2} \right) 2\pi dr$$

$$\Rightarrow v_{av} = \frac{1}{2\mu} \left( -\frac{dP}{dz} \right) \left[ \frac{R^2}{2} - \frac{R^4}{4R^2} \right]$$

$$\Rightarrow \bar{v} = \frac{1}{2\mu} \left( -\frac{dP}{dz} \right) \left( \frac{R^2}{4} \right)$$

$$\tau_w = \mu \left. \frac{dv}{dr} \right|_{r=R} = \mu \left( -\frac{dP}{dz} \right) \left( \frac{R^2}{4} \right) \left[ \frac{2r}{R^2} \right]_{r=R} = \mu \left( -\frac{dP}{dz} \right) \left( \frac{R}{2\mu} \right)$$

$$= \frac{1}{2\mu} \left( -\frac{dP}{dz} \right) \left( \frac{R^2}{4} \right) \left( \frac{4}{R} \right) \mu = \frac{4\mu\bar{v}}{R} = \frac{8\mu\bar{v}}{D}$$

$$h_f = \frac{4\tau_w}{\rho g} \frac{L}{D} = \frac{4}{\rho g} \frac{L}{D} \frac{8\mu\bar{v}}{D}$$

$$\Rightarrow h_f = \frac{32 \mu L \bar{v}}{\rho g D^2} \text{----- (3)}$$

Long back, Julius Weisback, a German Prof. In 1850, had shown that  $h_f \propto \frac{L}{D}$ . Hagen in his experiment had found that  $h_f \propto v^2$  (approx.). H. Darcy a French engineer proposed a dimensionless parameter, 'f' which is a function of  $(Re_d, \frac{\epsilon}{d}, \text{duct shape})$ .

$$h_f = f \frac{L}{D} \frac{\bar{v}^2}{2g} \text{----- (4)}$$

Rewriting Eqn. (3) in form of Eqn. (4), we have

$$h_f = \frac{L\bar{v}^2}{2gD} \left( \frac{\mu 64}{\rho\bar{v}D} \right) = \frac{L\bar{v}^2}{2gD} \left( \frac{64}{Re_D} \right)$$

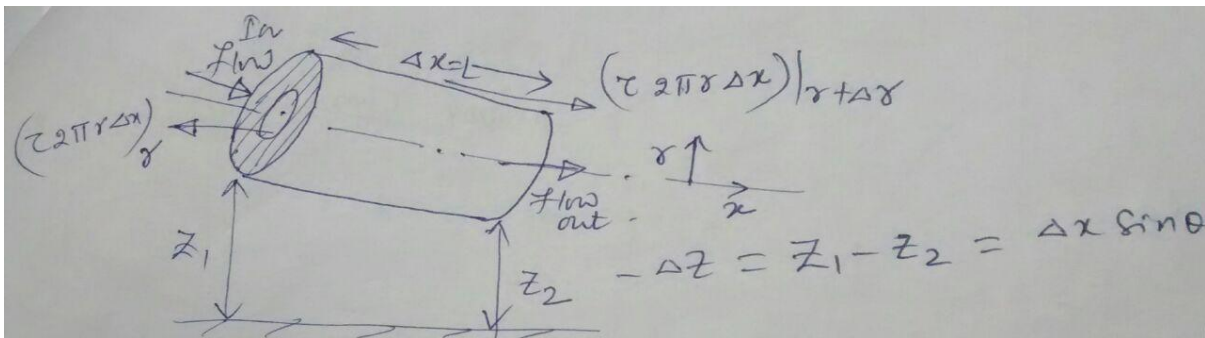

$$(P_x - P_{x+\Delta x}) 2\pi r \Delta r + 2\pi \Delta x [(\tau r)_{r+\Delta r} - (\tau r)_r] + \rho(2\pi r \Delta r \Delta x) g \sin \theta = 0$$

Dividing by  $2\pi r \Delta r \Delta x$

$$\Rightarrow \lim_{\Delta x \rightarrow 0} \left( \frac{P_x - P_{x+\Delta x}}{\Delta x} \right) + \frac{1}{r} \frac{\partial}{\partial r} (r\tau) + \lim_{\Delta x \rightarrow 0} \rho g \left( \frac{-\Delta z}{\Delta x} \right) = 0$$

# Fundamentals of Fluid Mechanics

$$\Rightarrow -\frac{dP}{dx} - \rho g \frac{dz}{dx} + \frac{1}{r} \frac{\partial}{\partial r}(r\tau) = 0$$

$$\Rightarrow \left(\frac{dP}{dx} + \rho g \frac{dz}{dx}\right) = \frac{1}{r} \frac{\partial}{\partial r}(r\tau) \text{----- (1)}$$

Let  $P = p + \rho g z$  where  $P \rightarrow$  modified pressure

$$\frac{dP}{dx} = \frac{dp}{dx} + \rho g \frac{dz}{dx}$$

Putting in Eqn. (1), we can write;

$$\frac{dP}{dx} = \frac{1}{r} \frac{\partial}{\partial r}(r\tau)$$

$$\text{Thus; } v = -\left(\frac{dP}{dx}\right) \left(\frac{R^2}{4\mu}\right) \left[1 - \frac{r^2}{R^2}\right]$$

Because of the gravity the local or/and average velocity increases for the above situation i.e both  $\frac{dp}{dx}$  &  $\frac{dz}{dx}$  are negative.

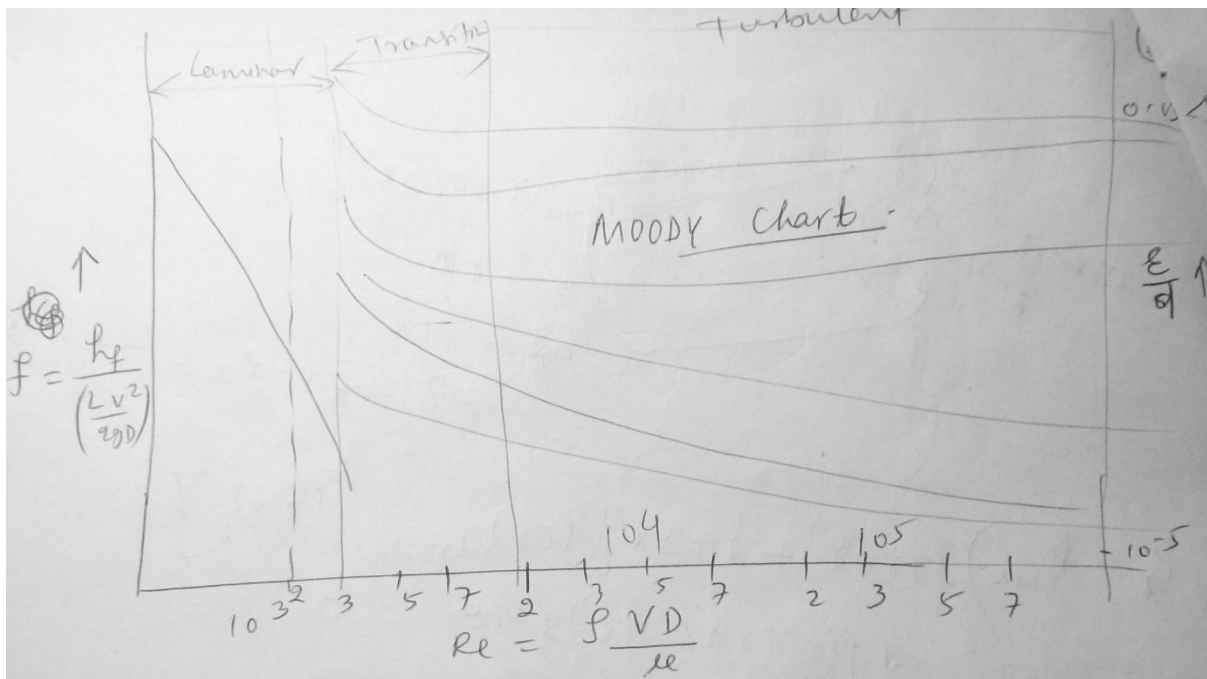

$\frac{\epsilon}{d} \rightarrow$  Relative roughness

**Example:-** Determine the head loss in friction when water flows at  $15^\circ\text{C}$  through a 300 mm long galvanized pipe  $d = 150$  mm &  $Q = 0.05$   $\text{m}^3/\text{s}$ .  $v = 1.14 \times 10^{-6}$   $\text{m}^2/\text{s}$ ,  $\epsilon = 0.15$  mm. Also find the pumping power required.

# Fundamentals of Fluid Mechanics

---

**Solution:-**  $R_e = \frac{\tau v D}{\mu} = \frac{v D}{\nu} = 3.72 \times 10^5$   $f = 0.02$

$$\text{Power} = \rho Q g h_f$$

The head lost due to friction is called major loss.

Minor losses:- Due to abrupt changes in geometry, shape of the pipes (i.e sudden expansion, contraction etc.), loss in mechanical energy occurs. In long ducts these losses are very small compared to the frictional loss, & hence they are termed as minor losses.

The minor head losses may be expressed as  $h_f = K \frac{\bar{v}^2}{2}$  where K is determined experimentally.

(a) Sudden contraction & Enlargements

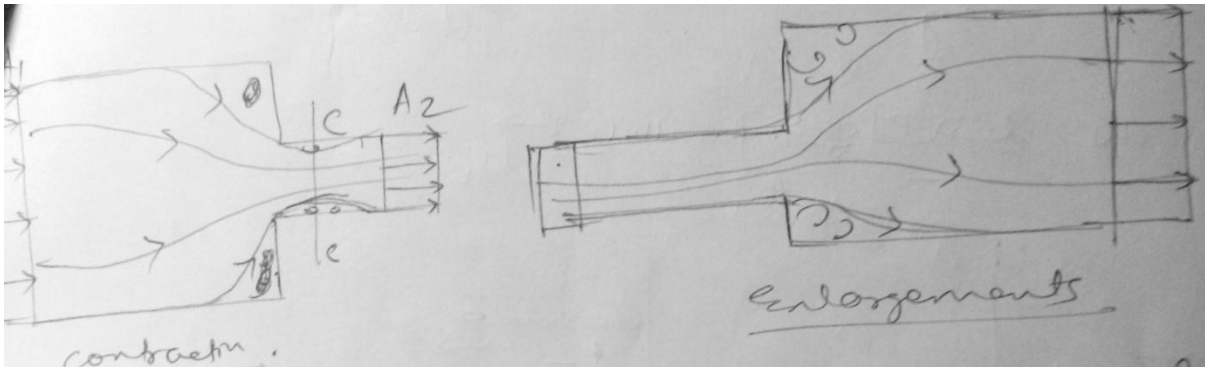

(b) Entry & Exit losses

(c) Pipe bends

(d) Valve & fittings

$$\text{Total loss} = l_f + h_w$$

Four cases for solving pipe problems:-

- a) L, Q & D known,  $\Delta P$  unknown
- b)  $\Delta P$ , Q & D known; L unknown
- c)  $\Delta P$ , L & D known; Q unknown
- d)  $\Delta P$ , L & Q known, D unknown

Flow through Branched pipes:-

(1) Pipes in series:

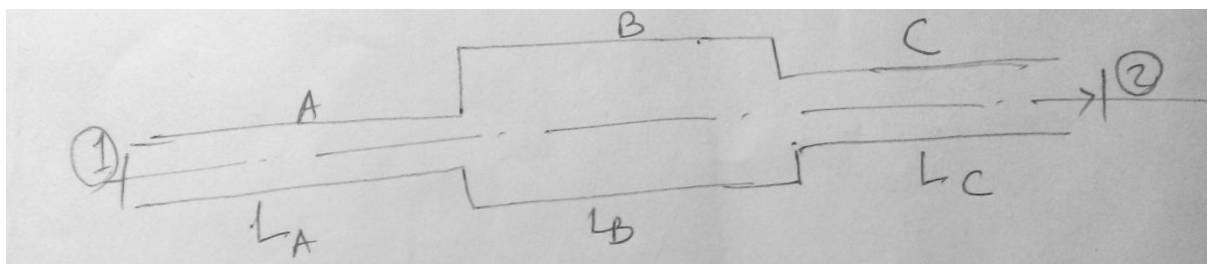

$$Q_A = Q_B = Q_C$$

$$h_t = h_{fA} + h_{en} + h_{fB} + h_{cont.} + h_{fc}$$

Where  $h_{fA} = \frac{fL_A v_A^2}{2gD_A}$  & so on, other pipes.

$$h_{en} = \frac{(v_A - v_B)^2}{2g} \quad \& \quad h_{cont.} = \frac{v_c^2}{2g} \left( \frac{1}{C_c} - 1 \right)$$

(2) Pipes in parallel:-

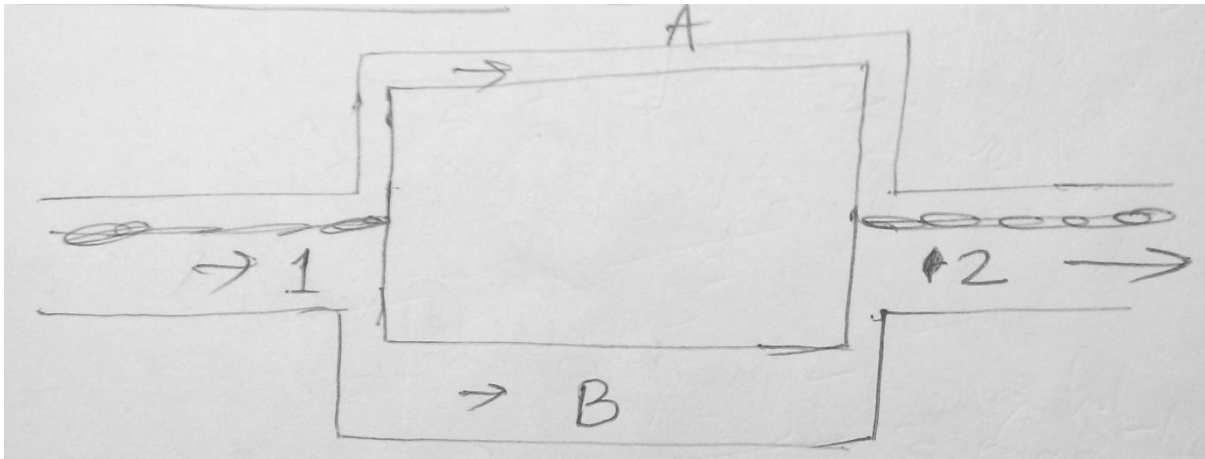

$$Q = Q_A + Q_B$$

$$h_t = H_1 - H_2 = f_A \frac{L_A}{D_A} \frac{v_A^2}{2g} = f_B \frac{L_B}{D_B} \frac{v_B^2}{2g}$$

Sudden Enlargement :

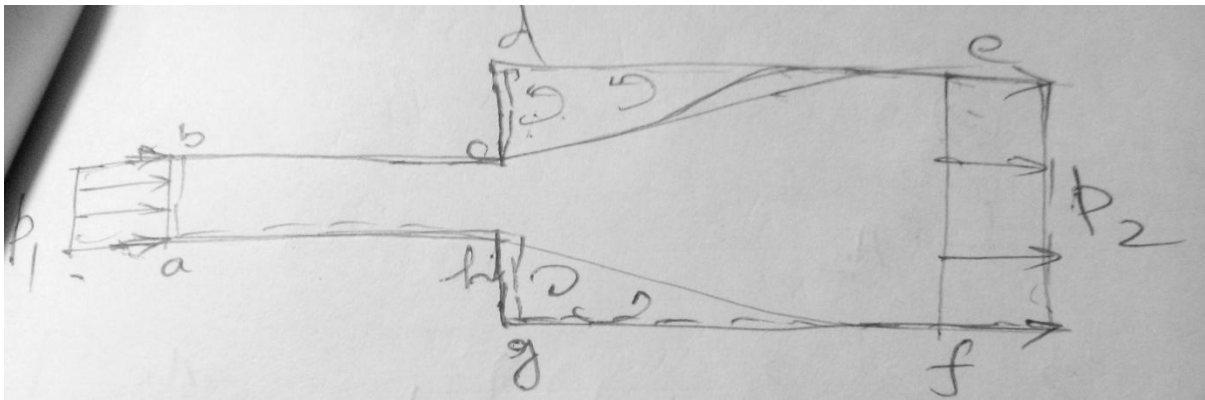

$$p_1 A_1 + p'(A_2 - A_1) - p_2 A_2 = \rho Q (v_2 - v_1)$$

From experimental evidence  $p' = p_1$ ; where  $p'$  is the mean pressure of the eddying fluid over the annular face g-d.

Thus;

$$p_1 A_1 + p_1 (A_2 - A_1) - p_2 A_2 = \rho Q (v_2 - v_1)$$

But;  $Q = A_1 v_1 = A_2 v_2$  (from continuity)

$$\Rightarrow (p_2 - p_1)A_2 = \rho A_2 v_2 (v_1 - v_2)$$

$$\Rightarrow p_2 - p_1 = \rho v_2 (v_1 - v_2)$$

From SFEE:

$$\frac{p_1}{\rho} + \frac{v_1^2}{2} = \frac{p_2}{\rho} + \frac{v_2^2}{2} + gh_2$$

$$\Rightarrow \frac{p_2 - p_1}{\rho} = \frac{v_1^2 - v_2^2}{2} - gh_2$$

$$\Rightarrow v_2 (v_1 - v_2) = \frac{v_1^2 - v_2^2}{2} - gh_2$$

$$\Rightarrow 2v_1 v_2 - 2v_2^2 = v_1^2 - v_2^2 - 2gh_2$$

$$\Rightarrow 2gh_2 = (v_1 - v_2)^2$$

$$\Rightarrow h_2 = \frac{(v_1 - v_2)^2}{2g} = \frac{v_1^2}{2g} \left[ 1 - \left( \frac{A_1}{A_2} \right) \right]^2$$

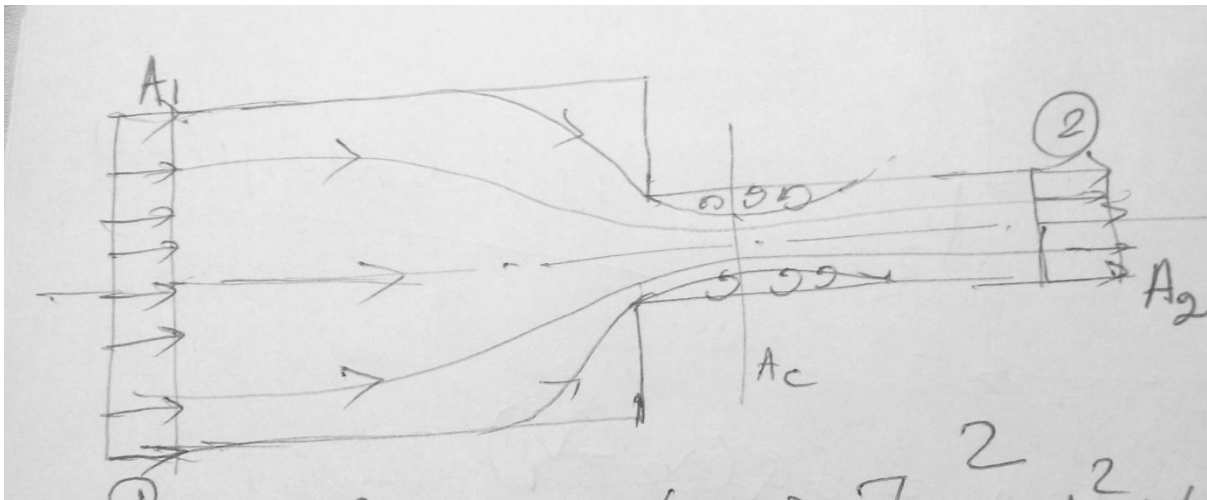

$$h_2 = \frac{v_c^2}{2g} \left[ 1 - \left( \frac{A_c}{A_2} \right) \right]^2 = \frac{A_2^2 v_2^2}{A_c^2} \times \frac{1}{2g} \left[ 1 - \frac{A_c}{A_2} \right]^2$$

$$\Rightarrow h_2 = \frac{v_2^2}{2g} \left[ \left( \frac{A_2}{A_c} \right) - 1 \right]^2 = \frac{v_2^2}{2g} \left[ \frac{1}{C_c} - 1 \right]^2$$

Where  $C_c = \frac{A_c}{A_2} =$  Coefficient of contraction



## # MEASUREMENT OF FLOW RATE THROUGH PIPE:

Flow rates in a pipe are usually measured by providing a co-axial area contraction within the pipe & by recording the pressure drop across the contraction. The flow rate can be determined from the pressure drop by straight forward application of Bernoulli's Eqn. Three such flow meters operate on this principle i.e

(i) Venturimeter (ii) Orificemeter (iii) Flow nozzle

### 1. Venturimeter:

$$\alpha_2 < \alpha_1$$

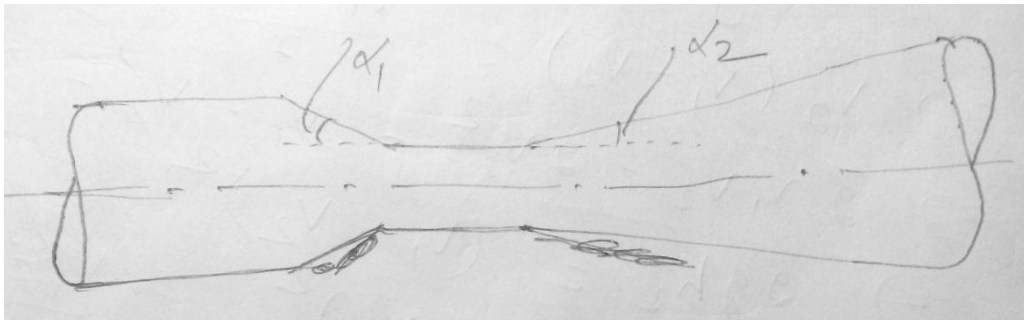
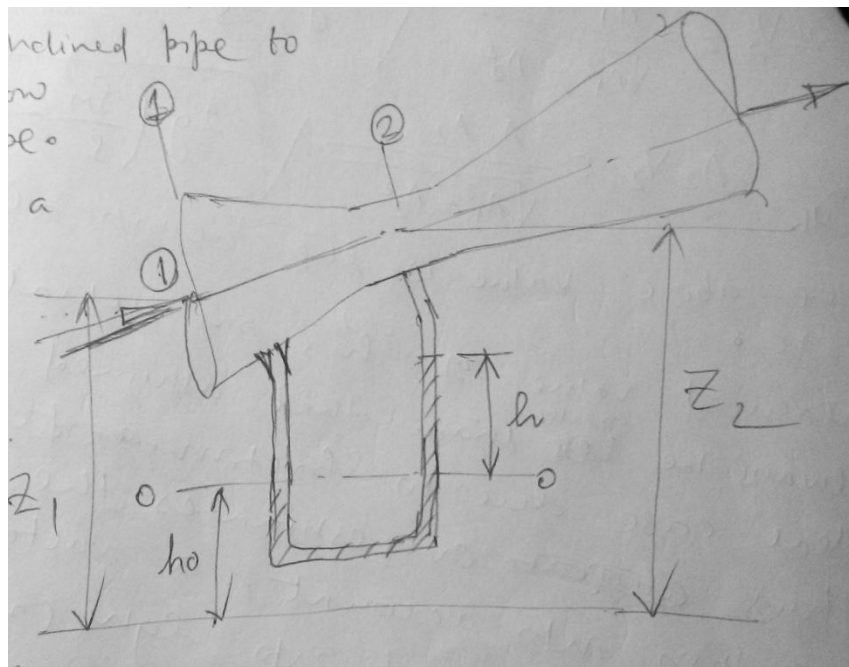

Figure shows a venturimeter inserted in a inclined pipe to measure the flow rate through pipe.

Let us consider a steady, ideal and one dimensional flow of fluid.



Applying Bernoulli's Equation.:

$$\frac{p_1}{\rho g} + \frac{v_1^2}{2g} + z_1 = \frac{p_2}{\rho g} + \frac{v_2^2}{2g} + z_2$$

$$\Rightarrow \frac{v_2^2 - v_1^2}{2g} = \frac{p_1 - p_2}{\rho g} + (z_1 - z_2) = \left( \frac{p_1}{\rho g} + z_1 \right) - \left( \frac{p_2}{\rho g} + z_2 \right) \text{----- (1)}$$

From pressure balance at section 0-0:-

$$p_1 + \rho g(z_1 - h_o) = p_2 + \rho g(z_2 - h - h_o) + \rho_m g h$$

$$\Rightarrow \left( \frac{p_1}{\rho g} + z_1 \right) = \left( \frac{p_2}{\rho g} + z_2 \right) + (\rho_m - \rho) h \times \frac{1}{\rho}$$

$$\Rightarrow \left( \frac{p_1}{\rho g} + z_1 \right) - \left( \frac{p_2}{\rho g} + z_2 \right) = (\rho_m - \rho) h \times \frac{1}{\rho} \text{----- (2)}$$

Putting the above value in Eqn. (1);

$$\frac{v_2^2 - v_1^2}{2g} = (\rho_m - \rho) h \times \frac{1}{\rho}$$

From continuity;  $A_1 v_1 = A_2 v_2$

$$v_1 = \frac{A_2 v_2}{A_1}$$

$$\text{Thus; } V_2^2 - \left( \frac{A_2}{A_1} \right)^2 V_2^2 = 2g \left( \frac{\rho_m}{\rho} - 1 \right) h$$

$$\Rightarrow V_2^2 = \frac{[2g \left( \frac{\rho_m}{\rho} - 1 \right) h]}{[1 - \left( \frac{A_2}{A_1} \right)^2]}$$

$$\Rightarrow V_2 = \frac{A_1}{\sqrt{A_1^2 - A_2^2}} \sqrt{2g \left( \frac{\rho_m}{\rho} - 1 \right) h}$$

$$Q_{th} = A_2 v_2 = \frac{A_1 A_2}{\sqrt{A_1^2 - A_2^2}} \sqrt{2g \left( \frac{\rho_m}{\rho} - 1 \right) h} \text{----- (3)}$$

The above value is the theoretical discharge/flow rate.

Measured value of 'h', in actual situation will always be greater than that assumed in case of ideal case due to friction. Thus overestimates the flow rate. To take this into account, a multiplying factor  $C_d$ , is incorporated in equation (3), i.e.,

$$Q_{act} = C_d \frac{A_1 A_2}{\sqrt{A_1^2 - A_2^2}} \sqrt{2g \left( \frac{\rho_m}{\rho} - 1 \right) h}$$

Value of  $C_d$  for venturimeter usually lies between 0.95 to 0.98. It is interesting to note that 'Q' remains same whether the pipe is inclined or horizontal.

## 2. Orificemeter:

$C_c = \frac{A_c}{A_o}$ ; where  $A_o$  is the area of the orifice.

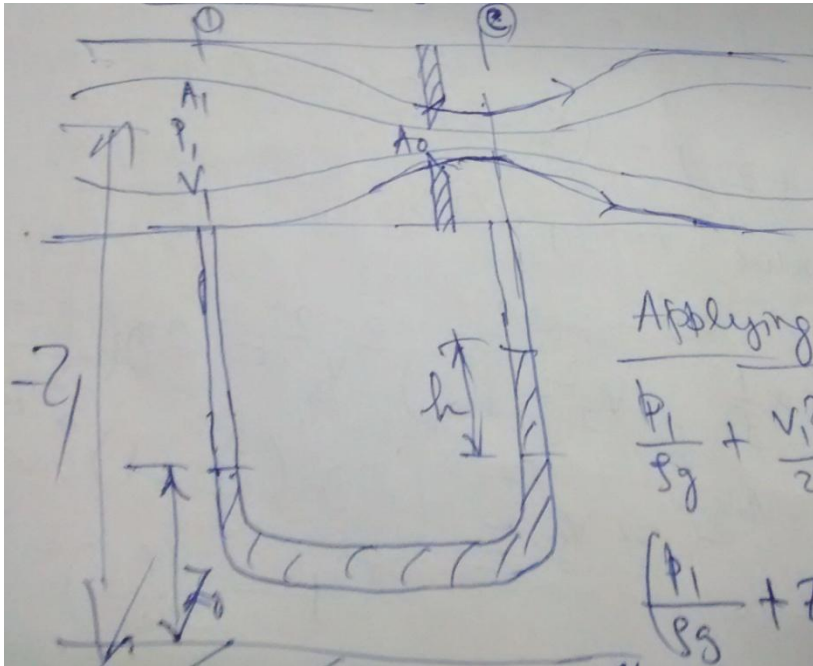

Applying Bernoulli's Equation between 1 and c.:

$$\frac{p_1}{\rho g} + \frac{v_1^2}{2g} + z_1 = \frac{p_c}{\rho g} + \frac{v_c^2}{2g} + z_c$$

$$\Rightarrow \frac{v_c^2 - v_1^2}{2g} = \left( \frac{p_1}{\rho g} + z_1 \right) - \left( \frac{p_c}{\rho g} + z_c \right) \text{----- (1)}$$

From pressure balance at section 0-0:-

$$p_1 + \rho g(z_1 - h_o) = p_2 + \rho g(z_2 - h - z_o) + \rho_m g h$$

$$\Rightarrow \left( \frac{p_1}{\rho g} + z_1 \right) = \left( \frac{p_2}{\rho g} + z_2 \right) + (\rho_m - \rho) h \times \frac{1}{\rho}$$

$$\Rightarrow \left( \frac{p_1}{\rho g} + z_1 \right) - \left( \frac{p_2}{\rho g} + z_2 \right) = (\rho_m - \rho) h \times \frac{1}{\rho} \text{----- (2)}$$

Putting the above value in Eqn. (1);

$$\frac{v_c^2 - v_1^2}{2g} = (\rho_m - \rho) h \times \frac{1}{\rho}$$

$$V_{cth} = \left[ \frac{[2g(\frac{\rho_m}{\rho} - 1)h]}{[1 - (\frac{A_c}{A_1})^2]} \right]^{\frac{1}{2}}$$

$$V_{cact} = V_{cth} \times C_v$$

$$Q_{act} = A_c V_{cact} = C_c A_o V_{cact} = C_c C_v A_o \left[ \frac{[2g(\frac{\rho_m}{\rho} - 1)h]}{[1 - (\frac{A_o C_c}{A_1})^2]} \right]^{\frac{1}{2}}$$

$$\Rightarrow Q_{act} = C_d A_o \left[ \frac{[2g(\frac{\rho_m}{\rho} - 1)h]}{[1 - (\frac{A_o C_c}{A_1})^2]} \right]^{\frac{1}{2}}$$

$$\text{Where } C_d = C_c C_v$$

Orificemeters are less accurate than venturimeters.

CHAPTER-5

①
②

Open channel flow / Flows with free surface

There are many situations where the upper surface of the liquid is not bounded by solid walls. Examples are Natural streams, rivers, canals etc. Pipes, lines or tunnels which are not completely full of liquid have also the essential features of open channels.

Flow in open channels: →

Geometrical Terminologies: -

Top Breadth (B): → It is the breadth of channel section at the free surface.

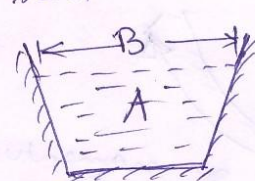
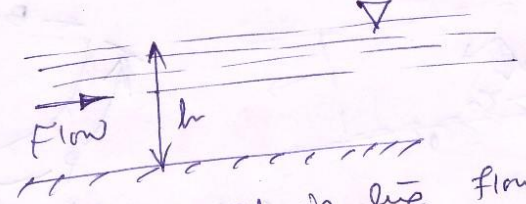
The water Area (A): → It is the flow cross-sectional area perpendicular to the direction of the flow.

Wetted perimeter (P): Perimeter of the solid boundary in contact with the liquid.

Hydraulic Radius (Rh): →  $R_h = \frac{A}{P}$

Types of flow in open channels: →

uniform flow: →  
 Cross-section & depth of flow don't vary along the length of the channel. →  $h = \text{const.}$   
 $v = \text{const.}$

non-uniform flow: →  
 Liquid surface is not parallel to the base of the channel. →  $h \text{ \& } v \text{ vary gradually}$

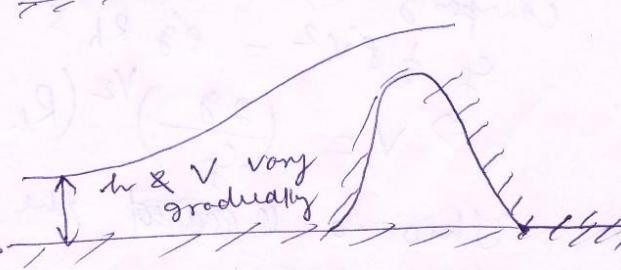

The flow may vary gradually or rapidly. (Example spillway of a dam). The flow may vary rapidly if the liquid is suddenly released by opening a spillway sluice gate.

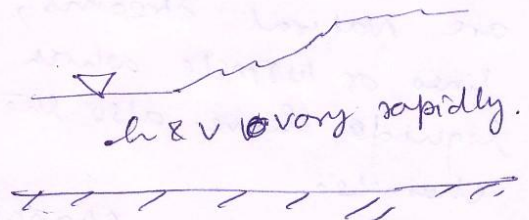

Steady uniform flow - The chezy eqn :-

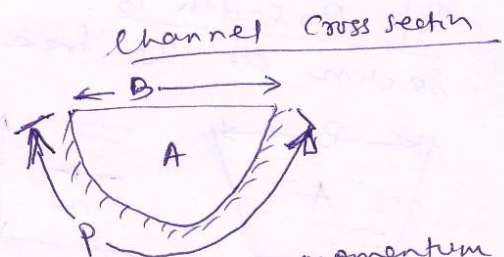
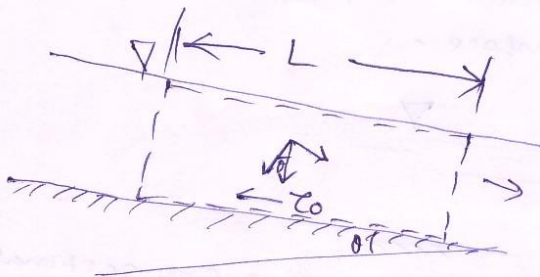

Net force acting on the C-V = Net rate of momentum efflux from C-V

$$W \sin \theta - \tau_0 P L = 0$$

$$\rho g A L \sin \theta = \tau_0 P L$$

$$\Rightarrow \tau_0 = \rho g \left( \frac{A}{P} \right) \sin \theta = \rho g R_h S \quad \text{--- (1)}$$

where  $S$  is the slope of the bed channel. We define a non-dimensional term:

$$C_f = \frac{\tau_0}{\frac{1}{2} \rho V^2} \quad \text{--- (2)}$$

Comparing (1) & (2) we have;

$$C_f \frac{1}{2} \rho V^2 = \rho g R_h S$$

$$\Rightarrow V = \left( \frac{2g}{C_f} \right)^{1/2} (R_h S)^{1/2} = C (R_h S)^{1/2} \quad \text{--- (3)}$$

This is the well known chezy eqn.

# Flow over Notches & Weirs

A notch may be defined as an opening provided on the side of a tank (or vessel) such that the liquid surface is below the top edge of the opening. Notches (made of metallic plates) are also provided in narrow channels (particularly in laboratory channels) to measure the flow rate of the liquid.

A weir is a concrete structure built across a river bed in order to raise the level of the water on the upstream side and to allow the excess water to flow over its entire length to the downstream side.

Classification of Notches & Weirs :-

Notches & Weirs may be classified as rectangular, triangular or Trapezoidal.

Flow over a rectangular sharp-crested weir or notch :-

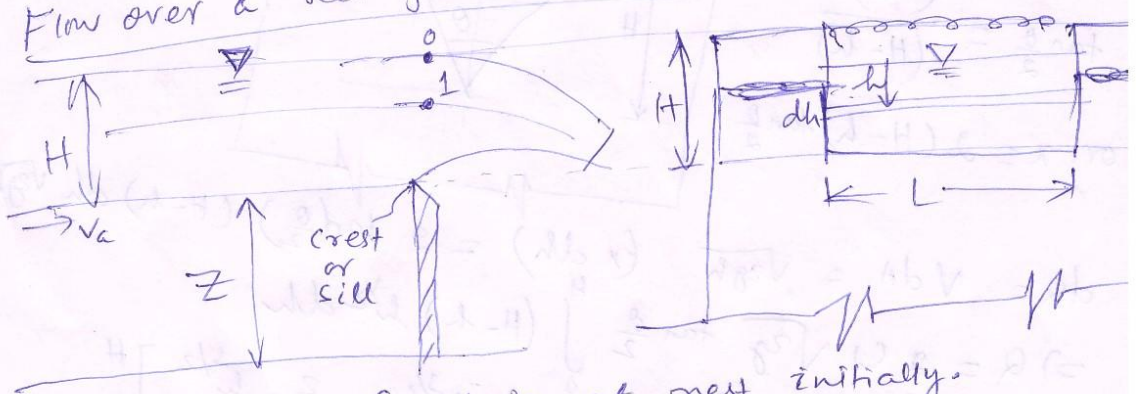

Consider the fluid is at rest initially.

Applying B's eqn between 0 & 1:

$$0 + h \rho g + P_{atm} = \frac{\rho V^2}{2g} + 0 + P_{atm}$$

$$\Rightarrow V = \sqrt{2gh}$$

If  $dQ$  is the discharge through the strip, then

$$dQ = C_d L dh \sqrt{2gh}$$

$$Q = \int_0^H C_d L \sqrt{2gh} dh = \frac{2}{3} C_d \sqrt{2g} L H^{3/2}$$

If  $V_a$  is the velocity of approach, then;

$$\frac{V_a^2}{2g} + h = \frac{V^2}{2g} \quad \text{or; } h_a + h = \frac{V^2}{2g}$$

$$\Rightarrow V = \sqrt{2g(h + h_a)}$$

$$Q = C_d L \int_{h_a}^H \sqrt{2g} (h + h_a)^{1/2} dh$$

$$= C_d L \int_{h_a}^{H+h_a} \sqrt{2g} x^{1/2} dx = \frac{2}{3} C_d \sqrt{2g} L \left[ (H+h_a)^{3/2} - h_a^{3/2} \right]$$

Trapezoidal Notch :-

$$\tan \frac{\theta}{2} = \frac{(x/2)}{(H-h)}$$

$$\text{or; } x = 2(H-h) \tan \frac{\theta}{2}$$

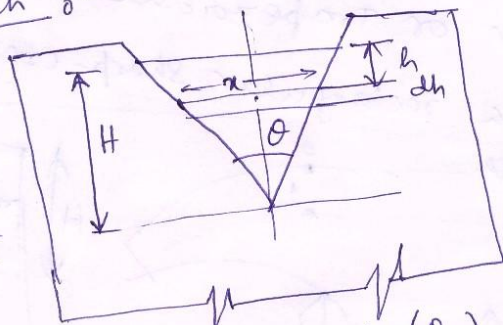

$$dQ = V dA = \sqrt{2gh} (x dh) = 2 \tan \left( \frac{\theta}{2} \right) (H-h) dh \sqrt{2gh}$$

$$\Rightarrow Q = 2 C_d \sqrt{2g} \tan \frac{\theta}{2} \int_0^H (H-h) h^{1/2} dh$$

$$\Rightarrow Q = 2 C_d \sqrt{2g} \tan \frac{\theta}{2} \left[ \frac{2}{3} H h^{3/2} - \frac{2}{5} h^{5/2} \right]_0^H$$

$$\Rightarrow Q = 2 C_d \sqrt{2g} \left( \tan \frac{\theta}{2} \right) \frac{8}{15} H^{5/2} = \frac{8}{15} C_d \sqrt{2g} \tan \frac{\theta}{2} H^{5/2}$$



The parameter  $C = \left(\frac{2g}{f}\right)^{1/2}$  is called the Chezy's coefficient & has dimension  $L^{1/2} T^{-1}$ . (5)

Variation of chezy coefficient :- To determine the velocity  $V$ , one has to know the value of  $C$  (the chezy coefficient). In case of flow through pipes  $f$  (friction factor) depends upon  $Re$  &  $\frac{\epsilon}{d}$ . However, in channel flow, the flow is fully turbulent & hence dependence of  $C$  on  $Re$  is negligible, while  $\frac{\epsilon}{R_h}$  becomes the only influencing parameter.

Experiments were made by several scientist/engineers to correlate the value of  $C$ . One such relation (empirical) is :-

$$C = \left(\frac{1}{n}\right) R_h^{1/6}$$

where 'n' is the roughness coefficient known as Manning's formula.

Putting these values in eqn (3), we get ;

$$V = \left(\frac{1}{n}\right) R_h^{2/3} S^{1/2} \quad \text{--- (4)}$$

Optimum Hydraulic Cross-section/Channel of Efficient flow

$$Q = \frac{A}{n} R_h^{2/3} S^{1/2} \quad \text{--- (5)}$$

We can observe in eqn (5) that;  $Q$  will be maximum if the wetted perimeter 'p' is minimum for a given C.S area (A). The most efficient cross-section from the hydraulic point of view, is semi-circular as it has the least wetted perimeter. It is also economical as the lining

material will be minimum for minimum  $P'$ .  
 The C.S of such a channel is known as optimum hydraulic C.S.

Although a semi-circular channel has the minimum hydraulic mean radius ( $R_h$ ), it is difficult to construct such C.S as it is made from prefabricated sections. Trapezoidal sections on the other hand are very popular. We should therefore find out the condition for maximum  $R_h$  for a trapezoidal C.S.

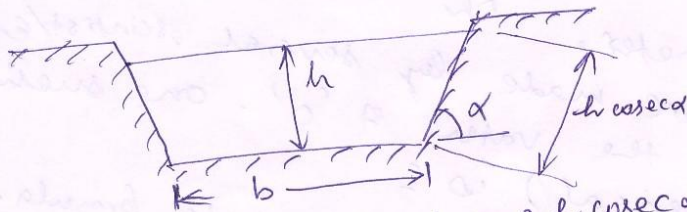

wetted perimeter;  $P = b + 2h \operatorname{cosec} \alpha$

C.S Area;  $A = \frac{1}{2} [b + b'] h$

$b' = b + 2 \left( \frac{h}{\sin \alpha} \right) \cos \alpha$

$A = \frac{1}{2} [b + b + 2h \cot \alpha] h = (b + h \cot \alpha) h$

$\Rightarrow A = bh + h^2 \cot \alpha$

$\Rightarrow b = \frac{A}{h} - h \cot \alpha$

$\& P = \frac{A}{h} - h \cot \alpha + 2h \operatorname{cosec} \alpha$

$R_h = \frac{A}{P} = \frac{\left( \frac{A}{h} \right) - h \cot \alpha + 2h \operatorname{cosec} \alpha}{\left( \frac{A}{h} \right) - h \cot \alpha + 2h \operatorname{cosec} \alpha}$

$R_h$  will be maximum, when  $P$  becomes minimum

$\frac{d}{dh} \left[ \left( \frac{A}{h} \right) - h \cot \alpha + 2h \operatorname{cosec} \alpha \right] = 0$

$\Rightarrow -\frac{A}{h^2} - \cot \alpha + 2 \operatorname{cosec} \alpha = 0$

(7)

$$\Rightarrow A = h^2 [2 \operatorname{cosec} \alpha - \cot \alpha]$$

$$R_h)_{\max} = \frac{h^2 (2 \operatorname{cosec} \alpha - \cot \alpha)}{h (2 \operatorname{cosec} \alpha - \cot \alpha) - h \cot \alpha + 2h \operatorname{cosec} \alpha}$$

$$\Rightarrow R_h)_{\max} = \frac{h}{2}$$

If  $\alpha = 90^\circ$  then it becomes a rectangle &  
 $A = 2h^2$  and  $b = 2 \frac{h^2}{h} = 2h$

# If instead of depth of flow, the side slope is varied, then:

$$\frac{d}{d\alpha} \left[ \left( \frac{A}{h} \right) - h \cot \alpha + 2h \operatorname{cosec} \alpha \right] = 0$$

$$\frac{d}{d\alpha} \cot \alpha = -\operatorname{cosec}^2 \alpha$$

$$\frac{d}{d\alpha} \operatorname{cosec} \alpha = -\operatorname{cosec} \alpha \cot \alpha$$

$$\text{Thus; } -h (-\operatorname{cosec}^2 \alpha) + 2h (-\operatorname{cosec} \alpha \cot \alpha) = 0$$

$$\Rightarrow \operatorname{cosec} \alpha [\operatorname{cosec} \alpha - 2 \cot \alpha] = 0$$

$$\operatorname{cosec} \alpha - 2 \cot \alpha = 0$$

$$\Rightarrow \operatorname{csc} \alpha = 2 \cot \alpha \quad \text{or } \alpha = 60^\circ$$

Thus for maximum  $R_h$ , for a given depth of flow, the trapezoidal section is half of a regular hexagon.

Specific Energy, critical Depth (8)

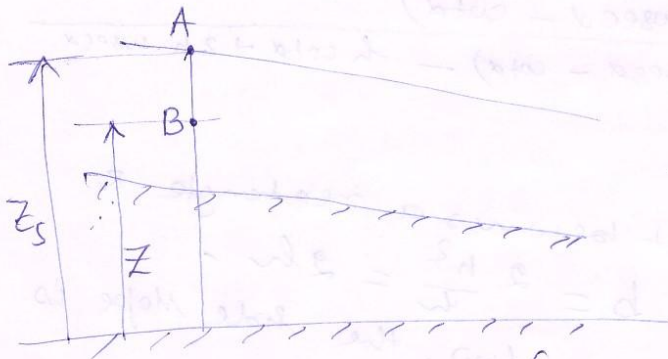

$$E_A = \frac{P_A}{\rho g} + \frac{V_A^2}{2g} + z_s = \left( \frac{P_{atm}}{\rho g} + z_s \right) + \frac{V_A^2}{2g} \quad \text{--- (1)}$$

$$E_B = \frac{P_B}{\rho g} + \frac{V_B^2}{2g} + z \quad \text{--- (2)}$$

But  $P_B = P_{atm} + \rho g (z_s - z)$

$$\frac{P_B}{\rho g} = \frac{P_{atm}}{\rho g} + (z_s - z)$$

Put in eqn (2),

$$E_B = \frac{P_{atm}}{\rho g} + z_s - z + z + \frac{V_B^2}{2g} = \left( \frac{P_{atm}}{\rho g} + z_s \right) + \frac{V_B^2}{2g}$$

If we denote  $h = \frac{P_{atm}}{\rho g} + z_s$ , then

$$E_s = h + \frac{V_{av}^2}{2g}$$

where,  $V_{av} = \frac{Q}{A} = \frac{Q}{bh} = \frac{q}{h}$  where  $q = \frac{Q}{b}$  if  $b$  is the width of the channel, then  $A = bh$

$$E_s = h + \frac{q^2}{2gh^2} = h + \left( \frac{q^2}{2g} \right) \frac{1}{h^2} \quad \text{--- (3)}$$

For the eqn (3), ~~three~~ out of three variables  $E_s$ ,  $h$  &  $q$ , any two may vary independently.

Case-I  $q$  keeps constant, we seek to see the variation between  $E_s$  &  $h$ . (9)

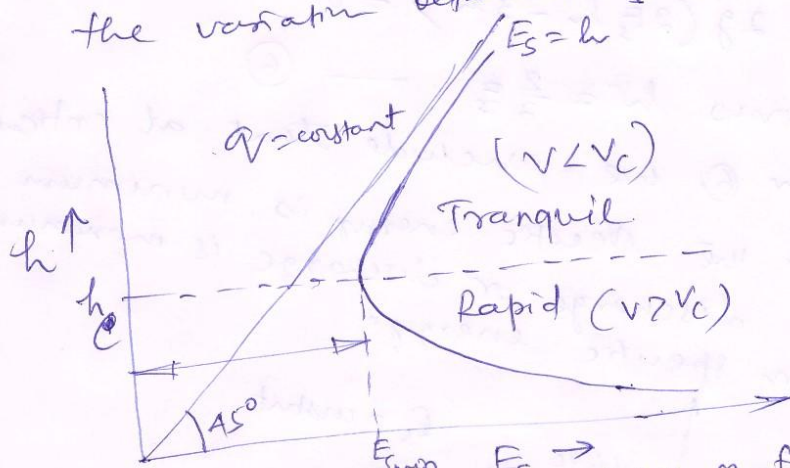

Variation of Sp. Energy w.r.t depth of flow for a given discharge

as  $h \rightarrow 0$ ,  $E_s \rightarrow \infty$  and the curve becomes asymptotic to  $E_s$  axis.  
 as  $h$  increases, the 2nd term in eqn (3), ~~becomes~~ ~~rectus~~ becomes insignificant and  $E_s$  varies directly with  $h$  & finally becomes asymptotic to the line  $E_s = h$ . Between these two extremes there exists a minimum value of  $E_s$ . The depth of flow corresponding to this minimum value of  $E_s$  is known as critical depth,  $h_c$ . The value of  $E_{smin}$  &  $h_c$  can be found out as follows: For  $E_s$  to be minimum, we can write:

$$\frac{\partial E_s}{\partial h} = 1 + \frac{q^2}{2g} \left( -\frac{2}{h^3} \right) = 0$$

$$\Rightarrow h_c = \left( \frac{q^2}{g} \right)^{1/3} \quad \text{--- (4)}$$

$$\text{the corresponding } E_{smin} = h_c + \frac{1}{2} \frac{h_c^3}{h_c^2} = \frac{3}{2} h_c \quad \text{--- (5)}$$

Case-II  $E_s$  constant,  $h$  &  $q$  varies.  
 $q^2 = 2gh^2 (E_s - h)$

For maximum discharge:

$$2q \frac{\partial q}{\partial h} = 2g(2E_s h - 3h^2) = 0$$

which gives  $h = \frac{2}{3} E_s$  — (6)

From eqn (5) or (6) we conclude that at critical depth, either the specific energy is minimum for a given discharge or discharge is maximum for a given specific energy.

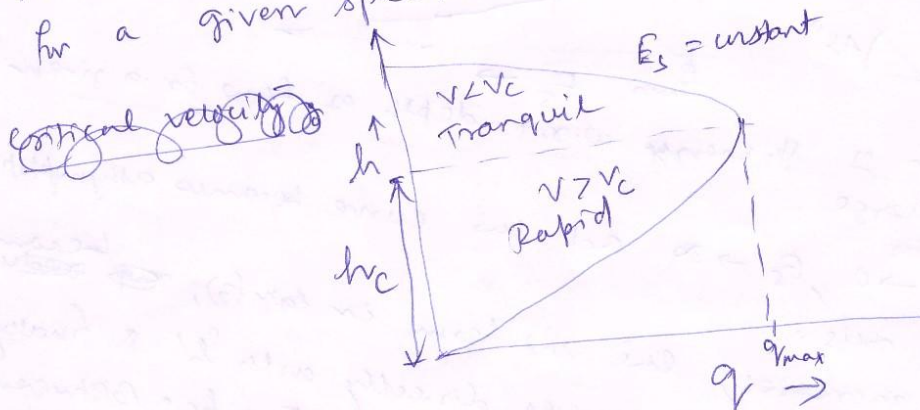

Critical velocity  $\rightarrow$  The velocity of flow at critical depth is known as critical velocity ( $V_c$ ).

Hence,  $V_c = \frac{q}{h_c} = \frac{(gh_c^3)^{1/2}}{h_c} = (gh_c)^{1/2}$

When  $h < h_c$ ;  $V > V_c$  is greater than  $V_c$

for case-I,  $q = \text{constant}$ .  
 $V = \frac{q}{h}$  or  $V \propto \frac{1}{h}$

So, when  $h > h_c$ ;  $V < V_c$ .

For case-II  $\rightarrow V = \frac{q}{h} = 2gh(E_s - h)$

$$V_c = 2g \times \frac{2}{3} E_s (E_s - \frac{2}{3} E_s) = \frac{4g}{9} E_s^2$$

Let  $V_1$  is the velocity, when  $h = h_c - \Delta h$   
 &  $V_2$  " , when  $h = h_c + \Delta h$

$$\begin{aligned}
 V_1 &= 2g \left[ \frac{2}{3} E_s - \Delta h \right] \left[ \frac{E_s}{3} + \Delta h \right] \quad \text{--- (1)} \\
 \Rightarrow V_1 &= g \left[ \frac{4}{9} E_s^2 + \frac{4}{3} E_s \Delta h - \frac{2}{3} E_s \Delta h - 2 \Delta h^2 \right] \quad \text{--- (1)} \\
 &= g \left[ \frac{4}{9} E_s^2 + \frac{2}{3} E_s \Delta h - 2 \Delta h^2 \right] \\
 V_2 &= 2g (h_c + \Delta h) (E_s - h_c - \Delta h) \\
 &= 2g \left[ \frac{4}{3} E_s + \Delta h \right] \left[ \frac{E_s}{3} - \Delta h \right] \\
 &= g \left[ \frac{4}{9} E_s^2 - \frac{4}{3} E_s \Delta h + 2 \frac{\Delta h E_s}{3} - 2 \Delta h^2 \right] \quad \text{--- (2)} \\
 &= g \left[ \frac{4}{9} E_s^2 - \frac{2}{3} E_s \Delta h - 2 \Delta h^2 \right] \quad \text{--- (2)}
 \end{aligned}$$

comparing (1) & (2)  $V_1 > V_2$   
 Thus when  $h > h_c$ ,  $v < v_c$  & vice-versa.

Water hammer  $\Rightarrow$

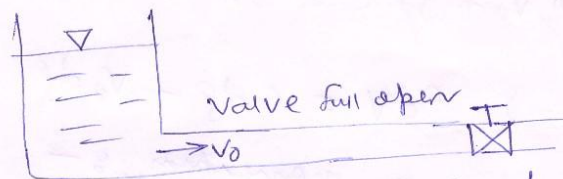

When the valve of a pipeline is suddenly closed, there will be a sudden change in pressure caused due to the change in velocity. This causes a knocking phenomenon on the pipe system due to propagation of pressure wave.

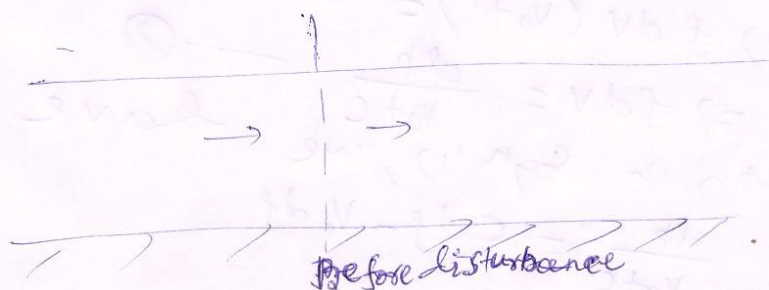

(12)

The analysis will be steady if the observer sets on the wave front & measures the velocity.

From continuity:  $\rho A (V_0 + c) = (\rho + \Delta\rho) A (V_0 + c - \Delta v)$

$$\Rightarrow \rho A V_0 + \rho A c = \rho A V_0 + \rho A c - \rho A \Delta v + A \Delta\rho V_0 + A c \Delta\rho - A \Delta v \Delta\rho$$

$$\Rightarrow \rho \Delta v = c \Delta\rho - V_0 \Delta\rho \quad \text{--- (1)}$$

From balance of momentum: -

$$\rho A p - (\rho + \Delta\rho) A (p + \Delta p) = -\rho A (V_0 + c)(V_0 + c) + (\rho + \Delta\rho) A (V_0 + c - \Delta v)(V_0 + c - \Delta v)$$

$$\Rightarrow -A \Delta p = \rho A (V_0 + c) \left[ -V_0 + V_0 + c - \Delta v \right]$$

$$\Rightarrow \rho \Delta v (V_0 + c) = \Delta p$$

$$\Rightarrow \rho \Delta v = \frac{\Delta p}{V_0 + c} \quad \text{--- (2)}$$

Putting in Eqn (1), we have

$$\frac{\Delta p}{V_0 + c} = c \Delta\rho - V_0 \Delta\rho$$



$$\Rightarrow dp = (v_0 + c) c ds - (v_0 + c) v_0 ds$$

$$\Rightarrow dp = \cancel{v_0} c ds + c^2 ds - v_0^2 ds - \cancel{c v_0} ds$$

$$\Rightarrow dp = c^2 ds - v_0^2 ds$$
$$= ds (c^2 - v_0^2)$$

$$\Rightarrow dp = ds c^2 \left[ 1 - \frac{v_0^2}{c^2} \right]$$

$$\text{Since } v_0 \ll c ; v_0^2 \ll c^2$$

$$\text{Thus } \boxed{c^2 = \frac{dp}{ds}}$$

## References:

1. Introduction to Fluid Mechanics by Fox and Mc Donald ,5<sup>th</sup> edition, Wiley.
2. Fluid Mechanics by F.M White, McGrawhill.
3. Introduction to Fluid Mechanics and Fluid Machines by Som and Biswas,2<sup>nd</sup> edition,Tata- McGrawhill.