

VEER SURENDRA SAI UNIVERSITY OF TECHNOLOGY, ODISHA, BURLA

(Formerly University College of Engineering, Burla)

Po: Engineering College, Burla, Dist: Sambalpur, Odisha, India, PIN: 768018

Phone: 0663-2430211, FAX: 0663-2430204, Website: www.vssut.ac.in



**Tender document for
Supply and furnishing of cot for Halls of Residence of the VSSUT**

Tender Call Notice No. VSSUT/ Registrar/ 294

Date: 10 /05/2019

Submitted by

M/s

**Last Date and Time of Receiving of Tenders : 03/06/2019 by 12PM
by Registered/Speed Post only**

Cost of Tender Documents : Rs 5000/-(Rupees Five Thousand Only)

Date & Time of Opening of Technical bid : 04/06/2019 at 11 AM

Date & Time of Opening of Price bid : 06/06/2019 at 11 AM

The Document is prepared by VSSUT, Burla. It should not be reused or copied or used either in partially or fully in any form. The information provided by the bidders in response to this tender document will become the property of VSSUT, Burla and will not be returned.



VEER SURENDRA SAI UNIVERSITY OF TECHNOLOGY: BURLA

P.O: Engineering College Burla (Siddhi Vihar), Dist: Sambalpur
Odisha– 768018, India

E-mail: registrar@vssut.ac.in, Ph:(0663)2430573,Fax-2430592

Advt.No.VSSUT/Registrar/294

Date: 10 /05/2019

TENDER CALL NOTICE

Sealed Tenders are invited by the undersigned from intending reputed, registered and experienced firms for Supply and furnishing of different furniture for Halls of Residence of the University. The last date of receiving of Tenders by Registered/Speed Post only is 03.06.2019, during office hours. The Technical & Financial bid shall be opened on 04.06.2019 and 06.06.2019 at 11.00 AM respectively. For details visit University website www.vssut.ac.in.

Sd/- Registrar

Memo No.VSSUT/REGISTRAR/ 295(5)

Dated: 10 .05.2019

Copy to :

1. M/s/ Display Lines, 219 Saheed Nagar, Bhubaneswar. The above advertisement may be published in all India edition of “The Samaj (Oriya Daily)”and all Odisha editions of “The Times of India (English Daily)” newspaper on 11.05.2019 in I & PR approved rates in one issue using minimum space. The bill may be sent in triplicate along with a copy of the paper in which the publications is made.
2. University Notice Board
3. Dean (Faculty & Planning) with a request to display the advertisement on the University website.
4. The Comptroller of Finance, VSSUT, Burla for Information.
5. PA to Vice Chancellor for kind information of Hon’ble Vice-Chancellor.

Sd/-

R E G I S T R A R

VEER SURENDRA SAI UNIVERSITY OF TECHNOLOGY, ODISHA, BURLA

**Tender Call Notice for
Supply and furnishing of different furniture for Halls of Residence of the VSSUT**

Tender Call Notice No. VSSUT/Registrar/ / Date: 10/05/2019

The “Registrar, Veer Surendra Sai University of Technology, Burla” invites sealed Tender from the intending reputed registered and experienced firms for Supply and furnishing of different furniture for Halls of Residence of the University.

All details and the tender documents are available on the University website www.vssut.ac.in.

This Tender document contains the following.

- i) Guidelines, terms and conditions
- ii) Information sheet of bidder
- iii) Undertaking by the bidder
- iv) Technical specification
- v) Technical bid
- vi) Financial bid

Important Dates

**Last Date and Time of Receiving of Tenders : 03/06/2019 by 12 PM
by Registered/Speed Post only**

Cost of Tender Documents : Rs 5000/-(Rupees Five Thousand Only)

Date & Time of Opening of Technical bid : 04/06/2019 at 11 M

Date & Time of Opening of Price bid : 06/06/2019 at 11 AM

Sd/-

Registrar

GUIDELINES, TERMS AND CONDITIONS

1. The bidder shall furnish an unconditional acceptance of all the terms and conditions of this tender call document. The tenders without such certificate shall be liable for rejection. No correspondence will be entertained from the bidder on this subject.
2. The person signing the tender or other documents shall indicate his full name below his signature and must specify whether he has signed as:
 - a. Sole Proprietor
 - b. Partner, in the case of Partnership firm (Who is empowered to sign such tenders, enter into agreement).
 - c. Director, in the case of a company, incorporated under the Indian Companies Act and duly authorized by the Board of Directors for the purpose.
 - d. Holder of Power of Attorney or authorized signatory
3. **Eligibility of the Bidder:** The bidder should verify its eligibility criteria as mentioned below before submitting the tender and enclose the required documents in the sequence listed below, to avoid rejection or disqualification of the tender document. The bidder should meet the following criteria.
 - a. The bidder shall have sufficient experience to execute such works preferably in a university or an educational organization. The Bidder must submit satisfactory evidence of their capability and adequacy of resources to carry out this contract effectively.
 - b. Bidder should be ISO certified
 - c. The bidder should be a GST registered dealers/company and profit making for the last three years. The bidder must have GST registration certificate, up-to-date GST return certificate, PAN and latest income tax return certificate etc.
 - d. The bidder shall have service base located at Odisha.
 - e. Turnover should be minimum fifty lakhs rupees annually for last three financial years duly certified by chartered accountant.
4. While every effort has been made to provide comprehensive and accurate background information and requirements and specifications, Bidders must form their own conclusions about the requirement.
5. All information supplied by Bidders may be treated as contractually binding on the Bidders, on successful award of the assignment by University on the basis of this tender.

6. **Cost of tender documents:** The cost of tender documents is Rs.5000.00 (Rupees Five Thousand only) (Non-refundable). The tender documents can be downloaded from the University website www.vssut.ac.in. A bank draft towards the cost of tender documents drawn in favor of “Veer Surendra Sai University of Technology, Burla” payable at SBI, Burla must be submitted along with tender document.
7. **Ernest Money Deposit (EMD):** A bank draft towards EMD of Rs. 40,000/- (Rupees forty thousand only) drawn in favor of “Veer Surendra Sai University of Technology, Burla” payable at SBI, Burla must be submitted. The EMD will not carry any interest.
8. The tender documents must be filled in completely and signed by the authorized signatory of the bidder on all the pages as acceptance of all the guidelines, terms and conditions laid in this tender document. (This document should be printed on both side of the A4 size paper sheet).
9. At any time prior to the last date for receipt of bids, VSSUT may, for any reason, whether at its own initiative or in response to a clarification requested by a prospective Bidder, modify the tender Document by a corrigendum.
10. The Corrigendum (if any) & clarifications to the queries from all bidders will be posted on the website of VSSUT www.vssut.ac.in.
11. Any such corrigendum shall be deemed to be incorporated into this tender.
12. In order to provide prospective Bidders reasonable time for taking the corrigendum into account VSSUT may, at its discretion, extend the last date for the receipt of Proposals.
13. **Submission of tender:** The bid should be submitted in a two cover format i.e. i) Technical Bid ii) Financial Bid
 - a. **Technical bid containing,**
 - i. This tender document signed on each page by the authorized signatory of the bidder.
 - ii. Self-attested copy of PAN, GST registration, up-to-date GST return certificate and latest income tax return certificate etc., issued by appropriate Government authority for the required services with seal of the tender.
 - iii. Bank draft (Non-refundable) towards the cost of tender documents in favor of Veer Surendra Sai University of Technology, Burla payable at SBI, Burla.
 - iv. Bank draft for EMD in favor of Veer Surendra Sai University of Technology, Burla payable at SBI, Burla.
 - v. List of user Clients and documents related to experience of the bidder along with address and contact number.
 - vi. Detailed specification of product along with the service support.

- vii. Detailed literature along with make, model, data sheets, pamphlets, drawing and performance curves as applicable shall be attached with the technical offer.
- viii. Any other documents in support of the eligibility of the bidder.
 - b. **Financial bid:** The financial bid shall specify the following,
 - i. Cost for **Supply and furnishing of different furniture for Halls of Residence of the VSSUT** as per specification. The bids submitted by telex/ fax/e-mail etc. shall not be considered. No correspondence will be entertained on this matter.
- 14. The completed document must reach to "The Registrar, Veer Surendra Sai University of Technology, Burla, PO. Burla, Dist. Sambalpur-768018 (Odisha) by the last date of submission i.e. by Office Hours under a sealed cover by registered/speed post only. The tender received after the due date & time is liable to be rejected.
- 15. The envelope containing the tender must be super-scribed as "Tender for **Supply and furnishing of different furniture for Halls of Residence of the VSSUT**" with due date & time of submission.
- 16. The University is not responsible for delay, loss or non-receipt of tender documents sent by post.
- 17. The tender document is not transferable. The tender submitted by the bidder in their own Performa shall not be accepted. While filling up the forms / offering any other information, it shall be done using ink/ball-point pen only or by typewriting. Tender document should be filled with neat and correct entries without overwriting.
- 18. It may be noted that one agency cannot represent or offer on behalf of more than one dealer in the particular proposal. Such proposals, if received will not be considered.

Price and its Validity

- 19. The tender shall contain the firm and final rates in clear and unambiguous terms in Indian Rupees.
- 20. The offered price must be inclusive of freight, packing, forwarding, transit insurance etc. for delivery at site. Execution of the furnishing work shall include of all supply, fabrication, installation & commissioning at the supplier cost.
- 21. The proposal and the offered prices shall be valid for 120 days from the date of opening the tender specified in the tender document.

Evaluation and Award of Contact

- 22. The University will evaluate the technical & financial aspects of the proposal. The University shall consider placement of orders for commercial supplies only on those

eligible bidder whose offers are found to be technically, commercially and financially acceptable and who have accepted the terms and conditions as stipulated in this tender document. The qualified vendors has to deposit and display sample of each item within 7 days of opening of technical bid for technical verification

23. On all the matters relating to this tender document, the decision of the University shall be final and binding and the same cannot be referred to the court of law. The University reserves the right to reject any or all of the tenders without assigning any reason what so ever.
24. The University reserves the right to call the bidders and to conduct negotiations, if necessary and has the right to select more than one bidder for one or more items at its discretion.
25. Any deviation in technical specifications shall not be entertained ordinarily. The University reserves the right to modify the specifications during the execution stage of the process. Wherever the technical specifications of items are changed either at the University request or at Bidder's request, revised price will be fixed, if necessary, by negotiations and as agreed upon by both parties.
26. The University reserves the right to order all or part or none of the items and/or services given in this document.
27. The University may reject the bid even if it is accepted but the successful bidder fails to execute any of the guidelines, terms and conditions mentioned in this tender document.
28. The supplier shall not assign or makeover the contract, the benefit or burden thereof to any other person or persons or body corporate. The bidder shall not underlet or sublet to any person(s) or body corporate for the execution of the contract or any part thereof.

Delivery Period, Installation and Commissioning

29. The vendor shall be liable to complete all the works of supply & installation as mentioned in scope of work at the site within 30 days from the date of receipt of the work order. The vendor is required to furnish an acceptance letter along with the work order copy within 7 days of receipt of the order.
30. In case the firm fails to complete the work within the due period, the University reserves the right to cancel the order and to place orders with other firms without assigning any reason thereof.

31. The firm must supply & install all ordered items at a time. Part supplies & installation are not acceptable and will not be entertained on any account. Any loss or damage during transit & execution shall be replaced at the cost of supplier.
32. If the vendor does not complete the job successfully within the stipulated date, it shall be open to the University to cancel the offer.

Warranty:

33. All the furnishing jobs completed as per order shall be covered by at least **one year warranty** from the date of commissioning of the project. However, if any individual component has warranty of more than one year offered by manufacturers, the same will prevail.
34. Free replacement/ repair of faulty parts including free technical support shall be provided during the warranty period. Warranty Certificate shall be submitted at the time of delivery.
35. 10% bank guaranty for one year (Warranty Period) should be provided by the firm.

Services

36. The vendor shall have a service base in Odisha preferably at Sambalpur / Rourkela/Angul/ Bhubaneswar and shall submit full detail address with phone no., fax no. and e-mail ID of the contact person for after sale service.

Billing and Payment

37. The vendor shall submit all bills in triplicate on printed forms to the University. The billing must be done with Odisha State GST billing.
38. The supplier must submit valid and up-to-date GSTCC and ITCC along with the bill before release of payment.
39. The University will make payments through account payee cheque drawn on SBI Burla, in Indian Rupees. No interest on any deferred claim arising out of this purchase shall be payable in any case whatsoever. No payment will be made for goods rejected at site during installation and commissioning.
40. The prices charged by the supplier for goods delivered and services performed under the contract shall not be higher from the prices quoted by the supplier in this offer. The 90% of the billed amount will be released only after satisfactory completion of the job as per the specifications. The balance 10% will be released after 90 days of the satisfactory on site performance from the final date of completion against performance security bank guaranty valid till the date of the warranty period.

Other terms and conditions

41. The University may cancel the order if it is found that the agency is blacklisted on previous occasions by any of the departments/ institutions/ local bodies etc.
42. The University may at any time terminate the contract by giving written notice to the vendor, without compensation to vendor, if the vendor becomes bankrupt or otherwise insolvent as declared by the competent court provided that such termination will prejudice or affect any right or action or remedy which has accrued or will accrue thereafter to the University.
43. Any dispute arising out of the deal shall be subjected to the jurisdiction of the court at Sambalpur within the State of Odisha.
44. The University reserves the right to add/delete/change any of the terms and conditions stipulated in this tender document.

Delivery as well as Billing Address

The Registrar,
Veer Surendra Sai University of Technology, Odisha
BURLA-768018, Dist. Sambalpur (Odisha)

Table-1 INFORMATION SHEET OF BIDDER

S/L	Description	To be filled in by the supplier
1	Name of the Vendor/Agency	
2	Address with phone No./FAX/ e-Mail	
3	Contact Person(s) Phone No. /Mobile No.	
4	Details of Bank Draft towards the cost of tender document	
5	Details of Bank Draft towards EMD	
6	Firm Registration Details	
7	GST registration details	
8	Experience details in supply of similar type of items in various organizations (Attach the proof copy)	
9	Yearly turnover (for last 3 years)	
10	Income tax and GST clearance certificate if any for the year ,2017-18, 2018-19 (attach copy)	

DECLARATION: We hereby certify that the information furnished above is full and correct to the best of our knowledge. We understand that in case any deviation is found in the above statement at any stage, the tender is liable to be rejected.

Undertaking by the Bidder

To
The Comptroller of Finance,
Veer Surendra Sai University of Technology,
Burla-768018.
Dist: Sambalpur, Odisha

Subject: Tender for "**Supply and furnishing of different furniture for Halls of Residence of the VSSUT**".

Dear Sir,

1. We have studied the full contents of the tender call document and agree to offer by the guidelines, terms and conditions laid in this tender document.
2. We enclose all the sheets of this tender call document duly signed by us on every page, as a token of accepting all the guidelines, terms and conditions laid in this tender document.
3. In case of non-observance of any of the guidelines, terms and conditions mentioned in this tender document by us, we understand that our offer/purchase order (as the case may be) may be cancelled.
4. We warrant that the goods supplied under this contract are new, unused, of the most recent or current models, and they incorporate all recent improvements in design and materials and all the services configured shall render trouble free function.
5. We hereby agree to **Supply and furnishing of different furniture for Halls of Residence of the VSSUT** as per the terms and conditions of this tender call document if we are offered to execute the contract.

Dated:

Signature of

In capacity of

Duly authorized to sign the tender for and on behalf of

Name and Address of the authorized Signatory

Signature:

Date:

TECHNICAL SPECIFICATIONS

S/N	Item Description & Specifications
1	Cots: 1828mm (L)×914mm (W) made by 25mm x 25mm x 5mm MS angle with four legs of 40 mm round MS steel hollow pipe fitted with 19mm commercial ply with provision for mosquito stand on the legs. The height of the cot shall be 457mm (H). Two numbers of 25mm x 25mm x 5mm angle intermediate support for the frame must be provided. The legs shall be strengthened by joining two legs with the help of 25mm round pipe on both the sides (Fig.1). Cot should be properly primed red and then painted with oven backed painting with proper anti rust treatment. Rubber buffer must be fixed to four legs. All sides or joints must be welded properly (Joining various parts with nuts and bolts is not allowed).

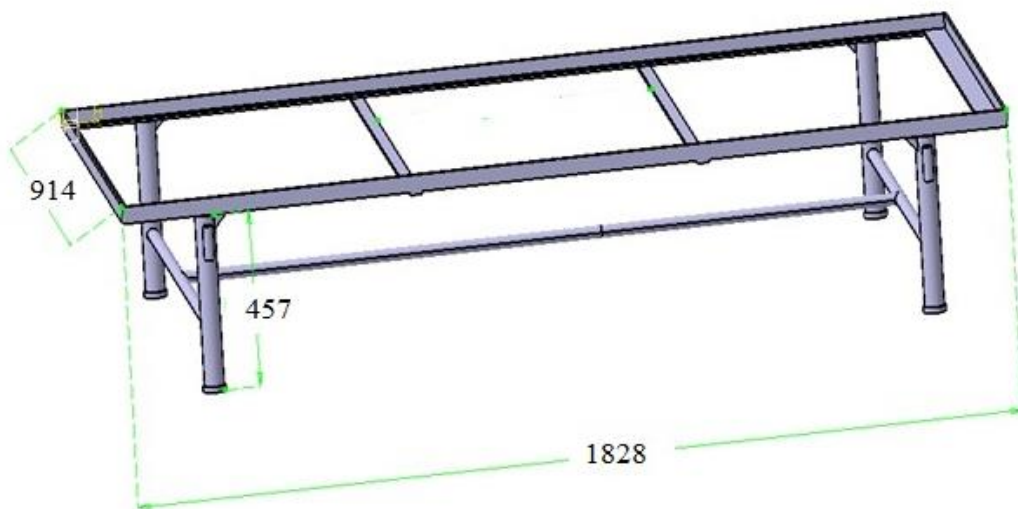

FIG.1- COT (Frame)

NB- Figures not to scale
All dimensions are in mm

TECHNICAL BID

To be filled and signed by the authorized signatory of the firm & this is to be put in separate sealed cover superscribed with **“Technical bid for Supply and furnishing of different furniture for Halls of Residence of the VSSUT**

”.

1	Name of the firm	
2	Address	
3	Contact No.	
4	Date of commencement of business	
5	PAN No. (Attach a copy)	
6	GST Clearance certificate (Attach a copy)	
7	Previous experience in the field (Attach proof)	
8	Warranty information.	Please attach list of items along with relevant warranty, if applicable
9	Product brochure/literature for each item	Attach copies of product brochure/literature for each item
10	Particulars of EMD attached	DDNo _____ Date _____ Amount <u>Rs.40,000/-</u> Issuing Bank Name _____

Signature of the Bidder with seal

FINANCIAL BID

To be filled & signed by the authorized signatory of the firm & this is to be put in separate sealed cover superscribed with “Financial bid for Supply and furnishing of different furniture for Halls of Residence of the VSSUT”.

S/N	Item Description & Specifications	Rate	Quantity *	Total Price
1.	Cots: Cot of size 1828mm (L)×914mm (W) made by 25mm × 5mm MS angle with four legs of 40 mm round MS steel hollow pipe fitted with IS mark moisture resistance 19mm commercial ply with provision for mosquito stand on the legs. The height of the cot shall be 457mm (H). Two numbers of 25mm angle intermediate support for the frame must be provided. The legs shall be strengthened by joining two legs with the help of 25mm round pipe on both the sides (Fig. 1). Cot should be properly primed red and then painted with oven backed painting with proper anti rust treatment. Rubber buffer must be fixed to four legs. All sides or joints must be welded properly (Joining various parts with nuts and bolts is not allowed).		550	
Taxes				
Grand Total (Inclusive of all taxes)				

* Approximate quantity may vary at the time of placing order.

Signature of the Bidder with seal